

ST23

ST26

ST35

Trimmers

Operator's Manual



TABLE OF CONTENTS

Table of Contents	1
Foreword	1
Safety Precautions	2
Metal Blade Use	6
Decal Information	7
Specifications	8
Parts Description	9
Trimmer Assembly	10
Fueling Instructions	12
Operation	14
Maintenance	17
Maintenance Chart	17
Troubleshooting Guide	24
Warranty	Back Cover

FOREWORD

This Operator's Manual contains safety precautions and operating procedures for the Cub Cadet Commercial line of trimmers. You must read and understand this Operator's Manual and especially the Safety Precautions for proper and safe operation.

Cub Cadet Commercial's philosophy is to continually improve all of its products. As a result, engineering changes and improvements are made from time to time. If the operating characteristics or the appearance of your trimmer differ from those described in this Operator's Manual, please contact your Cub Cadet Commercial dealer for information and assistance. Contact your Cub Cadet Commercial dealer if you do not understand any of the instructions in this manual.

Although hazard control and accident prevention are partially dependent upon the design and configuration of the trimmers, these factors are also dependent upon the awareness, concern, prudence and proper training of the personnel involved in the operation, transport, maintenance and storage of the trimmers.

WARNING

Indicates a strong possibility of severe personal injury or death if instructions are not followed.

CAUTION

Indicates a possibility of personal injury or equipment damage if instructions are not followed.

IMPORTANT:

This enclosed message provides information necessary for the protection of the unit.

NOTE:

This enclosed message provides tips for use, care and maintenance of the unit.



WARNING

The engine exhaust from this product contains chemicals known to the State of California to cause cancer, birth defects or other reproductive harm.

SAFETY PRECAUTIONS

GENERAL:

1. It is important that you read, fully understand and observe the following safety precautions and warnings. Read the Operator's Manual and the safety instructions periodically.
2. Do not lend or rent out your trimmer without the Operator's Manual. Be sure that anyone using your trimmer understands the information contained in this Operator's Manual.
3. Careless or improper use of this trimmer may cause serious or even fatal injury.
4. The use of the trimmer can be hazardous. If the rotating cutting line or a blade comes in contact with your body, it will cut you. When it comes in contact with solid foreign objects such as rocks or bits of metal, it may fling them directly or by ricochet in the direction of bystanders or the operator.
5. Cub Cadet Commercial does not recommend the use of rigid blades when cutting in stony areas. Thrown objects or damaged blades may result in serious or fatal injury to the operator or bystanders.

PHYSICAL CONDITION: You must be in good physical condition and mental health and not under the influence of any substance (drugs, alcohol, etc.) which might impair vision, dexterity or judgment. Do not operate the trimmer when you are fatigued.

1. Be alert - if you get tired while operating your trimmer, take a break. Fatigue may result in loss of control. Working with the trimmer can be strenuous. If you have any condition that might be aggravated by strenuous work, check with your doctor before operating the trimmer.
2. Prolonged use of the trimmer (or other machines) exposing the operator to vibrations may produce whitefinger disease (Raynaud's phenomenon) or carpal tunnel syndrome. These conditions reduce the hand's ability to feel and regulate temperature, produce numbness and burning sensations and may cause nerve and circulation damage and tissue necrosis. Antivibration systems do not guarantee that you will not sustain whitefinger disease or carpal tunnel syndrome. Therefore, continual and

regular users should monitor closely the condition of their hands and fingers. If any of the above symptoms appear, seek medical advice immediately.

PROTECTIVE CLOTHING: Trimmer operation can cause serious injury to eyes, ears and body. The deflector provided with your trimmer may not protect the operator from all foreign objects (gravel, glass, wire, etc.) thrown by the rotating cutting line or blade. Thrown objects may also ricochet and strike the operator.

1. Clothing must be sturdy and snug-fitting, but allow complete freedom of movement. Avoid loose-fitting jackets, scarfs, neckties, jewelry, flared or cuffed pants, unconfined long hair or anything that could become caught on branches, brush or moving parts of the unit. Wear long pants made of heavy material to protect your legs. **DO NOT WEAR SHORTS.**
2. To reduce the risk of injury to your eyes, never operate the trimmer unless wearing goggles or properly fitted safety glasses with adequate top and side protection complying with ANSI Z 87.1.
3. To reduce the risk of injury to your face Cub Cadet Commercial recommends that you also wear a face shield or face screen over your goggles or safety glasses.
4. Trimmer noise may damage your hearing. Wear sound barriers (ear plugs or ear mufflers) protect your hearing. Continual and regular user should have their hearing checked regularly.
5. Protect your hands with gloves when handling the trimmer. Heavy-duty, nonslip gloves improve your grip and protect your hands.
6. Good footing is most important in trimmer work. Wear sturdy boots with nonslip soles. Steel-toed safety boots are recommended.
7. Wear an approved safety hard hat to reduce the risk of injury to your head.

PROTECTING OTHERS:

1. Minors should never be allowed to use the trimmer.

SAFETY PRECAUTIONS

2. Spectators, children, fellow workers and animals must be warned to stay back 50 feet (15m) while the trimmer is in use. Stop the engine and cutting head immediately if you are approached.
3. People working in the area near you should wear the same protective equipment as the operator.

PREPARATION FOR THE USE OF THE TRIMMER:

1. Never modify the trimmer in any way. Only attachments supplied by Cub Cadet Commercial or expressly approved by Cub Cadet Commercial for use with the specific Cub Cadet Commercial trimmer models are authorized. Although certain unauthorized attachments are usable with the Cub Cadet Commercial trimmer, their use may, in fact, be extremely dangerous.
2. When transporting your trimmer in a vehicle, properly secure it to prevent turnover, fuel spillage and damage to the trimmer.
3. Always use the shoulder harness when using rigid blades.
4. Adjust the shoulder harness and hand grips to suit your size before starting work.
5. Always check your trimmer for proper condition and operation before starting, particularly the throttle trigger, throttle trigger interlock, stop switch, cutting head or blade, deflector and harness.
6. The throttle trigger must move freely and always spring back to the idle position. The cutting head must be properly tightened and in safe operating condition. Inspect for loose parts (nuts, screws, etc.).

HANDLING FUEL: The Cub Cadet Commercial trimmer uses an oil-gasoline mixture for fuel.

1. Gasoline is an extremely flammable fuel. If spilled and ignited by a spark or other ignition source, it can cause fire, serious burn injury and property damage. Use extreme caution when handling gasoline or an oil-gasoline fuel mixture.
2. Do not smoke or bring any fire or flame near the

fuel.

3. Fuel your trimmer outdoors or in a well-ventilated area.
4. Select bare ground for fueling and move at least 10 feet (3 m) from the fueling spot before starting the engine.
5. Gasoline vapor pressure may build up inside the gas tank of a two cycle engine depending on the fuel used, the weather conditions, and the venting system of the tank. In order to reduce the risk of personal injury from escaping gas vapor and fumes, remove the fuel filler cap on your trimmer carefully so as to allow any pressure buildup in the tank to release slowly.
6. Never remove the fuel filler cap while the engine is running.
7. Unit vibrations can cause an improperly tightened fuel cap to loosen or come off permitting fuel to spill. In order to reduce the risk of fuel spillage and fire, tighten the fuel cap by hand with as much force as possible.
8. Wipe off any spilled fuel before starting your trimmer.
9. Check for fuel leakage while refueling and during operation. If fuel or oil leakage is found, do not start or run the engine until the leak is fixed and spilled fuel has been wiped away.
10. If fuel spills on your clothing, change your clothing immediately.

CARBON MONOXIDE HAZARDS:

1. If you operate the trimmer in an area that is confined, or even partially enclosed, the air you breathe could contain a dangerous amount of exhaust gas. To keep exhaust gas from building up, provide adequate ventilation.
2. The exhaust gas contains carbon monoxide, a poisonous, colorless and odorless gas. Breathing the exhaust gas can cause loss of consciousness and may lead to death.

SAFETY PRECAUTIONS

STARTING: Your trimmer is a one-person machine.

1. Start and operate your trimmer without assistance. When starting, place the trimmer on firm ground or a solid surface in an open area. Maintain good balance and secure footing.
2. To reduce the risk of injury from loss of control, be absolutely sure that the cutting head or blade is clear of you and all other obstructions and objects, including the ground when starting, because when the engine starts, the engine speed will be fast enough for the clutch to engage and turn the cutting head or blade.
3. When you pull the starter grip, do not wrap the starter rope around your hand. Do not allow the grip to snap back, but guide the starter rope to rewind properly. Failure to follow this procedure may result in injury to your hand or fingers and may damage the starter mechanism.

OPERATION:

1. Work carefully.
2. To reduce the risk of injury from thrown objects or blade contact, never operate the trimmer without a properly mounted deflector.
3. Operate the trimmer under good visibility and daylight conditions only.
4. Always hold the trimmer firmly with both hands. Wrap your fingers tightly around the handles, keeping the handles cradled between your thumb and forefinger. Keep your hands in this position, to have your trimmer under control at all times.
5. Make sure your trimmer handles and grips are in good condition and free of moisture, pitch, oil or grease.
6. Never attempt to operate the trimmer with one hand. You might lose control of the trimmer resulting in serious or fatal injury.
7. To reduce the risk of bodily injury resulting from loss of control and contact with the cutting head, always attach and wear the shoulder harness on those trimmers equipped with a straight shaft and loop handle.

8. Before trimming, inspect the area for stones, glass, pieces of metal, trash or other solid objects. The cutting line could throw objects of this kind.
9. This trimmer is to be used normally at ground level with the cutting head or blade parallel to the ground. Using the trimmer above ground level or with the cutting head or blade perpendicular to the ground may increase the risk of injury, since the cutting line or blade is more fully exposed and the trimmer may be more difficult to control. Never use your trimmer as a hedge trimmer.
10. When using rigid blades, avoid cutting close to fences, sides of buildings, tree trunks, stones or other such objects that could cause the trimmer to kick out or could cause damage to the blade. Cub Cadet Commercial recommends use of the nylon line heads or Polycut head for such jobs. In addition, be alert to an increased possibility of ricochets in such situations.
11. Do not use the starting throttle lock when you are trimming as you do not have control of the engine speed. For the proper use of the throttle lock, see "Starting" in the Operation Section.
12. If the cutting tool or deflector becomes clogged or stuck, always turn off the engine and make sure the cutting tool has stopped, before cleaning. Grass, weeds, etc. should be cleaned off the cutting tool at regular intervals.
13. During cutting, check the tightness and the condition of the cutting tool at regular intervals. If the behavior of the tool changes, stop the engine immediately, and check the bolt securing the tool for tightness and the cutting tool for cracks and damage.
14. Replace cracked, bent, warped, damaged or dull cutting blades immediately. Such tools may shatter at high speed and cause serious or fatal injury.
15. A loose blade may cause the blade to crack, vibrate, break or come off the trimmer, which may result in serious or fatal injury. Make sure that the blade is properly tightened. Use the wrench supplied or one of sufficient length to obtain the proper torque. If the blade loosens after being properly tightened, stop work

SAFETY PRECAUTIONS

immediately. The retaining bolt may be worn or damaged and should be replaced. Never use unauthorized parts to secure the blade. If the blade continues to loosen, see your Cub Cadet Commercial dealer. Never use a trimmer with a loose blade.

16. To reduce the risk of personal injury from loss of control, do not use an incorrect idle adjustment. At correct idle speed, the head and line or blade should not move. For instructions on adjusting the idle speed, see "Carburetor Adjustment" in the Maintenance Section.
17. Never touch a rotating cutting tool with your hand or any part of your body. It continues to rotate for a short period after the throttle trigger is released.
18. Always turn off the engine and make sure the cutting line has stopped before putting the trimmer down.

METAL BLADE USE

WARNING

Specified deflector shield, bicycle handle and shoulder harness **MUST** be used on brushcutter with metal blades. Operating the brushcutter without specified deflector, shield, bicycle handle, and shoulder harness can cause serious personal injury.

WARNING

If blade is mounted improperly, it may come loose during operation and cause serious or fatal injury.

REQUIRED PARTS.....Parts List on 3,4 page

- A. Blades; 23,26cc; 1.IM-195833140 2.IM-195833170 3.IM-195833230
35cc; 1.IM-195833150 2.IM-195833070 3.IM-195833160
- B. Deflector; 4.IM-720463430
- C. Handle; 5.590541
- D. Shoulder Harness; 6.IM-720853461

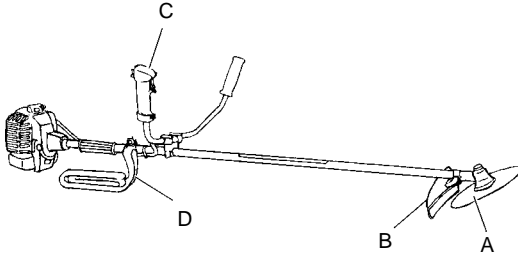
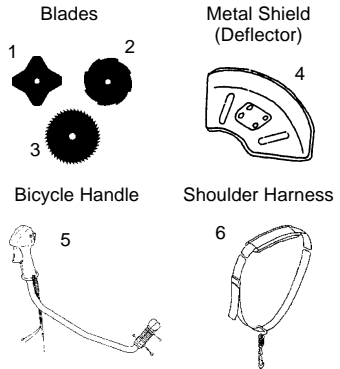

WARNING

Always wear hearing, eye, foot and leg protection when operating trimmer.

WARNING

Blade coasts after throttle release, maintain control and stop blade by contact with cut materials before the unit is set down.

WARNING

Read Operator's manual. Follow **ALL** warning and safety instructions. Failure to do so can result in serious personal injury to the operator and / or bystanders.

DECAL INFORMATION

WARNING

LOCATE THE SAFETY DECALS ON YOUR TRIMMER. MAKE SURE THE DECALS ARE LEGIBLE AND THAT YOU UNDERSTAND AND FOLLOW THE INSTRUCTIONS ON THEM.

DEFLECTOR DECAL:



SHAFT DECALS:



This trimmer can be dangerous and cause serious injury if improperly used. To reduce injury risk to operator, helpers and bystanders, read and understand the Operator's Manual.



Blindness can occur from objects that are thrown or ricochet even with a shield in place. Operators, helpers and by-standers must wear ANSI Z87.1 approved eye protection.

Always wear hearing protection when operating a trimmer.

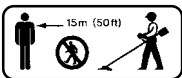

Prevent accidental contact with the trimmer and any cutting attachment. Maintain a 50 ft. (15m) radius, **DANGER ZONE** surrounding the operator. **ONLY** the operator, dressed in proper protective clothing should be in the **DANGER ZONE**.

SHAFT DECALS: (Continued)



Beware of **KICKOUT (blade thrust)** when using blades. Special precautions are necessary for blade operation, see your Operator's Manual. Install **ONLY** Cub Cadet Commercial approved blades on ST model trimmers equipped with proper blade shield, loop handle, shoulder harness, blade collar, nut and cotter pin.



The blade/cutting attachment does not stop immediately after releasing the throttle. Keep hands and feet clear of the blade/cutting attachment unless the engine is shut off and the cutting attachment is not moving.

INSPECT BLADES BEFORE USE.

DO NOT USE DAMAGED, CRACKED, BENT, DULL, OR IMPROPERLY SHARPENED BLADES.

Do not remove shields or decals, modify the unit or install unapproved attachments or parts. Approved attachments and replacement Operator's Manuals are available from your Cub Cadet Commercial dealer or by writing:

CUB CADET CORPORATION

P.O.Box 368023, Cleveland, OH 44136-9723

SPECIFICATIONS

Model		ST23 Loop Handle	ST26 Loop Handle	ST35 Loop Handle
Length	(mm)	1783	1783	1818
	(in.)	70.1	70.1	71.5
Width	(mm)	260	260	260
	(in.)	10.2	10.2	10.2
Height	(mm)	250	264	277
	(in.)	9.84	10.4	10.9
Weight	(kg)	4.8	5.1	6.7
	(lb.)	10.5	11.2	14.7
Type of Engine	Air-cooled, two-stroke, single cylinder gasoline engine.			
Bore	(mm)	33	33	37
	(in.)	1.3	1.3	1.46
Stroke	(mm)	26	30	32
	(in.)	1.02	1.18	1.26
Displacement	(cc)	22.2	25.6	34.4
	(cu. in.)	1.35	1.56	2.1
Engine Power	(ps/rpm)	1.02/8000	1.22/7500	1.63/7500
Carburetor	All position diaphragm carburetor with priming pump.			
Exhaust System	Spark arrester muffler.			
Ignition System	Flywheel magneto. (Electronic)			
Spark Plug	NGK BPMR7A			
Fuel	Mixed (gasoline and oil).			
Fuel/Oil Ratio	50:1 Using Cub Cadet Commercial 2-Stroke Engine Oil. 25-30:1 Using Other Brands of TC Oil.			
Fuel Tank Capacity (lit)		0.45	0.55	0.65
	(U.S. fl. oz.)	15.2	18.6	22.0

TRIMMER ASSEMBLY

The trimmer is partly disassembled for ease of shipment and must be assembled before it can be used for the first time.



WARNING

Because of the increased risk of accidents the powerhead must not be started while it is detached from the trimmer.

A. MOUNTING THE LOOP HANDLE:

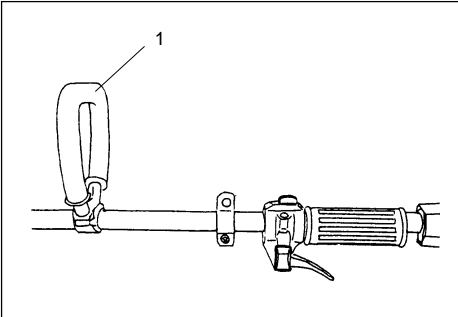

1. Mount the loop handle (Ref. 1) .

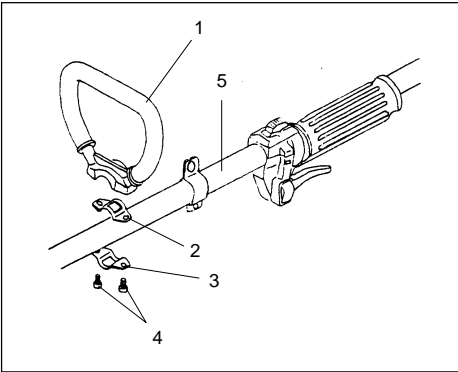

2. Position the clamp (Ref. 2) in the loop handle (Ref. 1).
3. Place both parts on the drive tube (Ref. 5).
4. Position the clamp (Ref. 3).
5. Insert the screws (Ref. 4) hand tight.

6. Line up the loop handle and tighten the screws firmly.

B. MOUNTING THE DEFLECTOR:

1. To mount the deflector, lay the trimmer on its back with the cutting tool head facing upward.

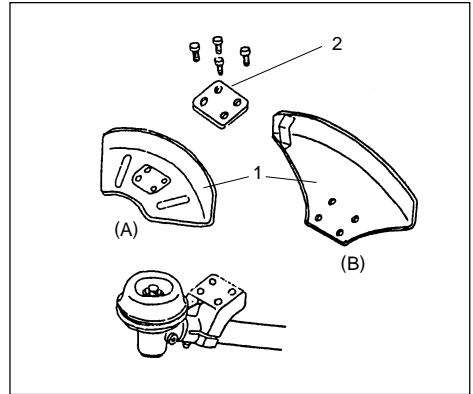

2. Place the deflector (Ref. 1) inside pointing upward, on the bracket already fitted to the drive shaft. Fit the plate (Ref. 2) on the inside of the deflector and line it up. Insert the four screws and tighten them down.
3. When using the nylon line trimmer, attach the deflector (B) with a chopper blade on your brushcutter in order to keep the line at the proper length. Failure to follow this procedure may damage your brushcutter.



WARNING

To reduce the risk of injury from thrown objects or blade contact, never operate the trimmer without a properly mounted deflector.

C. MOUNTING THE CUTTING TOOL:

1. Install the nylon line trimmer head or the cutting blade as illustrated.

TRIMMER ASSEMBLY



WARNING

If the nylon line trimmer head or the blade is fitted improperly, it may come loose during operation and cause serious or fatal injury.

Installing the Nylon Line Trimmer Head

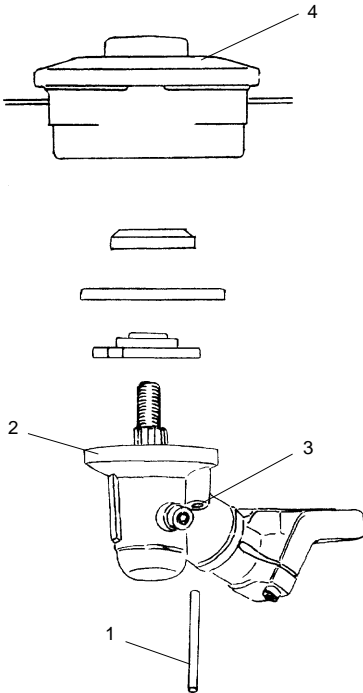

WARNING

Protect your hands with gloves if mounting a rigid blade.

2. Align the hole in the holder (Ref. 3) with the hole in the gear case (Ref. 2) and install the locking tool (Ref. 1).
3. Fit the nylon line trimmer head (Ref. 4) onto the shaft (turning it counterclockwise) until it is tight.
4. Remove the locking tool.

D. USING THE SHOULDER HARNESS (Standard on ST35):

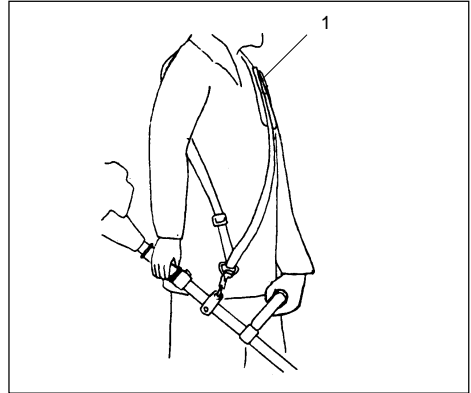

1. Put on the shoulder strap (Ref. 1).



WARNING

Always use the shoulder harness when using rigid blades.

Installing steel blade

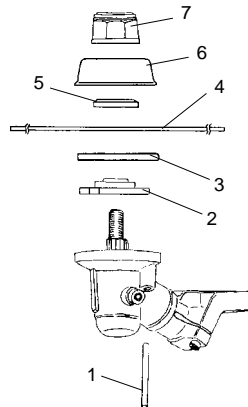

1. Install the selected cutting blade as illustrated.
2. Align the hole in the holder (Ref.2) with the hole in the gearcase and install the locking tool (Ref.1).
3. Install cover (Ref.3).
4. Install cutting blade (Ref.4).
5. Install holder (Ref.5).

FUELING INSTRUCTIONS

6. Install the bolt cover (Ref.6).
7. Install the left hand nut (Ref.7) tighten to 18.5 (N·m).

 **WARNING**

Reread the Safety Precautions relating to "Handling Fuel" on Page 3.

The Cub Cadet Commercial trimmer uses an oil-gasoline mixture as fuel. The engine is certified to operate on unleaded gasoline.

Use regular name-brand unleaded gasoline with a minimum octane number of 89. If the octane number of the regular grade gasoline in your area is lower use premium unleaded fuel. Fuel with a lower octane number may result in preignition (causing "pinging") which is accompanied by an increase in engine temperature. This, in turn, increases the risk of piston seizure and damage to the engine.

The chemical composition of the fuel is also important. Some fuel additives not only detrimentally affect elastomers (carburetor diaphragms, oil seals, fuel lines etc.), but magnesium castings as well. This could cause running problems or even damage the engine. For this reason it is essential that you use only name-brand fuels!

IMPORTANT:
Do not use any gasoline containing alcohol. Serious engine or fuel system damage will occur.

Use only quality two-stroke, air-cooled engine oil with the classification TC. The mix ratio is 25-30:1.

We recommend Cub Cadet Commercial brand 2-Stroke Engine Oil since it is specially tested for use in all Cub Cadet Commercial two-stroke engines. The mix ratio is 50:1

IMPORTANT:
Do not use BIA or TCW (two-stroke water cooled) mix oils!

Directions for Mixing: (See Chart for Amounts)

1. Put one-half of the gasoline in a safety approved container.

2. Add the proper amount of two-stroke oil and mix thoroughly.
3. Add the remainder of the gasoline and mix thoroughly.

Take care when handling gasoline. Avoid direct contact with the skin and avoid inhaling fuel vapor.

The gasoline container should be kept tightly closed in order to prevent any moisture getting into the mixture.

Only mix sufficient fuel for a few days work, not to exceed 30 days of storage. Store in a safety approved fuel container only.

Fuel Mixes:

Gasoline	Oil (50:1) (Cub Cadet 2-Stroke Engine Oil)	Oil (25-30:1) (Other Name-Brand TC Oils)
Liters (U.S. gal.)	Liters (U.S. fl. oz.)	Liters (U.S. fl. oz.)
1 (1)	0.02 (2.6)	0.04-0.033 (5.12-4.27)
10 (2.5)	0.2 (6.4)	0.4-0.33 (12.8-10.66)
20 (5)	0.4 (12.8)	0.8-0.67 (25.6-21.33)

Dispose of empty two-stroke oil containers at authorized disposal locations only.

 **CAUTION**

The engine used on this trimmer is of a 2-cycle design. The internal moving parts of the engine, f.e., crankshaft bearings, piston pin bearings and piston to cylinder wall contact surfaces, require oil mixed with the gasoline for lubrication. Failure to add oil to the gasoline or failure to mix oil with the gasoline at the appropriate ratio will cause major engine damage which will void your warranty. For your fuel premix, only use Cub Cadet Commercial brand 50:1 2-cycle oil or a quality oil designed for 2-cycle air cooled engines.

FUELING INSTRUCTIONS

FUEL MIXTURE :

When using Cub Cadet Commercial 50:1 2-cycle brand oil, or a quality oil designed for 2-cycle air-cooled engines, oil ratio is 50 parts gasoline to 1 part oil or 50:1.



CAUTION

Never use a mixing ratio greater than 50:1 regardless of the oil package mixing instructions. Ratios greater than 50:1, (for example, 60:1, 80:1, 100:1), reduce the amount of lubrication to the internal moving parts of the engine and can cause damage.

MIXING INSTRUCTIONS :

Always mix fuel and oil in a clean container approved for gasoline. Mark the container to identify it as fuel mix for the trimmer. Use regular unleaded gasoline and fill the container with half therequired amount of gasoline. Pour the correct amount of oil into the container then add the remaining amount of gasoline. Close the container lightly and shake it momentarily to evenly mix the oil and the gasoline before filling the fuel tank on the trimmer.

When refilling the trimmer fuel tank, clean around the fuel tank cap to prevent dirt and debris for entering the tank during cap removal. Always shake the premix fuel container momentarily before filling the fuel tank.

Always use a spool or funnel when fueling to reduce fuel spillage. Only fill the tank to within 1/4-1/2 inch from the top of the tank. Avoid filling to the top of the tank filler neck.

NOTE:

1. Never mix gasoline and oil directly in the trimmer fuel tank.
2. Check for fuel leakage around the tank cap and the fuel tank before the operation.



CAUTION

1. Do not use National Marine Manufacturer's Association (NMMA) or BIA certified oils. This type of 2-cycle engine oil does not have the proper additives for air-cooled, 2-cycle engines and can cause engine damage.
2. Do not use automotive motor oil. This type of oil does not have the proper additives for air-cooled, 2-cycle engines and can cause engine damage.

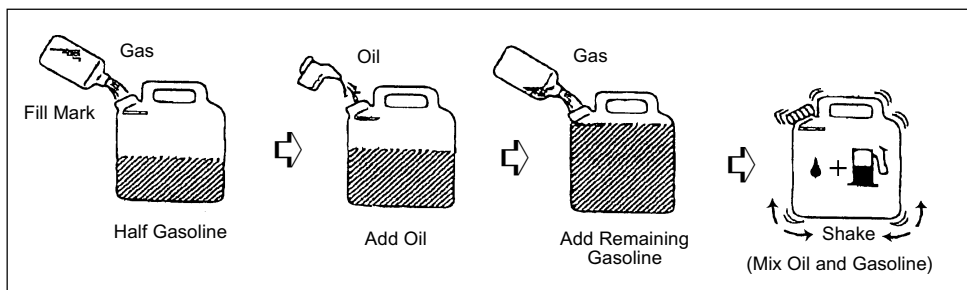

OPERATION

A. STARTING:

WARNING

Reread the Safety Precautions relating to "Starting" on Page 3.

WARNING

When the engine starts, the cutting tool may rotate even with the throttle trigger in the low-speed position possibly causing injury.

1. When the Engine is Cold.

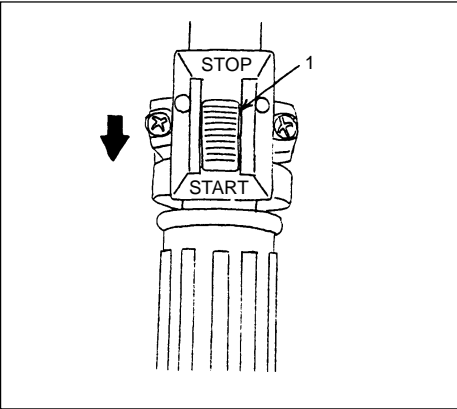

a. Slide the ignition switch (Ref.1) to the "START" position. (Away from the arrow.)

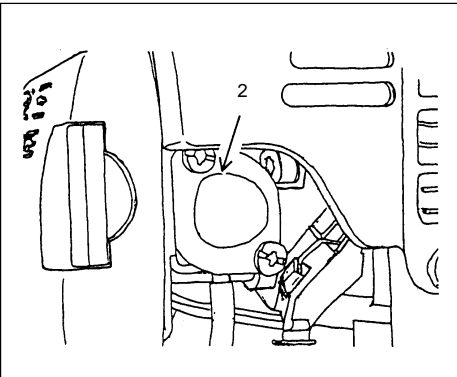

b. Push the priming pump (Ref. 2) several times.

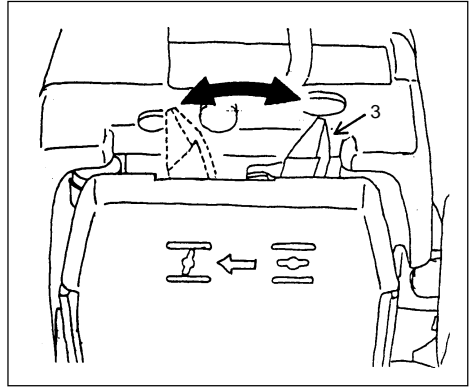

c. Close the choke (Ref.3) completely.

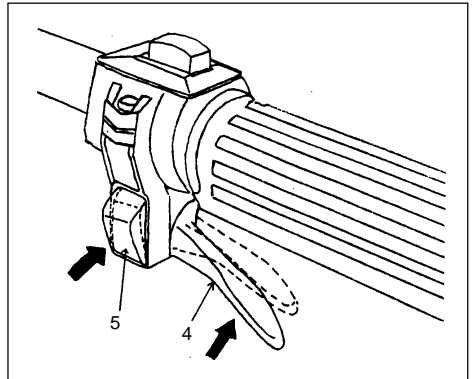

d. Grasp the throttle trigger (Ref.4) fully, then release it slowly while pushing the lock button (Ref.5). This sets the throttle trigger at half-throttle.

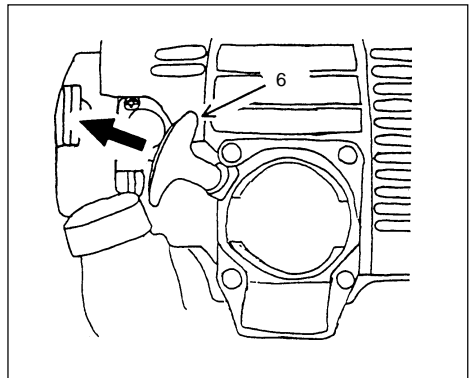

- e. Put the unit on the ground:
It must rest securely on the engine support and deflector. Check that the cutting tool is not touching the ground or any other obstacles.
- f. Make sure you have a firm footing:
Hold the unit with your left hand and press it down firmly. Do not stand or kneel on the drive shaft.
- g. Pull the starter grip:
When pulling the starting rope (Ref. 6), use short pulls, 1/2 to 2/3 of the rope length.
Do not let the starter grip snap back - guide it slowly into the housing so that the starter rope can rewind properly.
- h. Grasp the trigger immediately after the engine is started. This releases the lock button and automatically sets the engine to idle.

2. When the Engine is Warm.

Restarting the engine after it has been stopped.

- a. Slide the ignition switch to the **“START”** position.
- b. Push the priming pump several times.
- c. Set the choke lever to the **“FULL OPEN”** position.
- d. Pull the starter grip.

NOTE:

If the engine does not start after four pulls, use the cold start procedure.

3. If the Engine Doesn't Start.

- a. If you did not move the choke lever to the **“FULL OPEN”** position quickly enough after the engine began to fire, the combustion chamber has flooded.

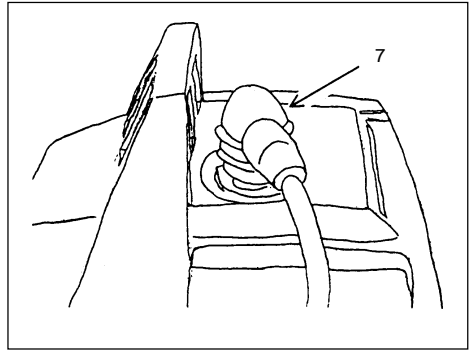

- b. Remove the spark plug wire (Ref. 7).
- c. Unscrew and dry off the spark plug.
- d. Set the ignition switch to **“STOP”**.
- e. Open the throttle fully .
- f. Pull the starter rope several times to clear the combustion chamber .
- g. Refit the spark plug and connect the spark plug wire.
- h. Set the ignition switch to **“START”**.
- i. Set the choke lever to **“FULL OPEN”**.
- j. Now start the engine.

OPERATION

B. STOPPING:

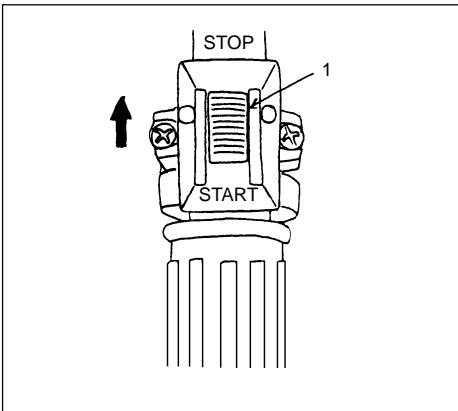

1. Return the throttle to the “**IDLE**” position and let the engine run for 2 or 3 minutes until it has cooled down.
2. Slide the ignition switch (Ref.1) to the “**STOP**” position.



WARNING

Reread the Safety Precautions relating to “Operation” on Page 4.

MAINTENANCE

NOTE:
MAINTENANCE, REPLACEMENT, OR REPAIR OF THE EMISSION CONTROL DEVICE AND SYSTEMS MAY BE PERFORMED BY ANY NONROAD ENGINE REPAIR ESTABLISHMENT OR INDIVIDUAL.

MAINTENANCE CHART							
PART	MAINTENANCE	BEFORE USE	MONTHLY	YEARLY	IF FAULTY	IF DAMAGED	SEE PAGE
Complete Machine	Visual Inspection (Condition, Leaks)	X					24
	Clean	X					
Control Handle	Check Operation	X					10
Fuel Filter	Check		X				23
	Replace			X			
Carburetor	Adjust				X		18,19
Cooling System	Clean	X					21,22
Muffler	Check		X				22
	Clean				X		
Fuel Leakage	Check	X					3
	Repair					X	
Fuel Lines	Check		X				23
	Replace					X	
Clutch and Clutch Drum	Check/Clean			X			22
	Replace					X	
All Accessible Screws and Nuts (Not Adjusting Screws)	Retighten	X					3
Cutting Tools	Visual Inspection	X					4,5,6
	Replace					X	
	Sharpen Metal Cutting Tools				X		4
	Check Tightness of Cutting Tool	X					4,9,10,11
Gearbox Lubrication	Check		X				23
	Fill Full			X			
Drive Shaft Lubrication	Check		X				23
	Replenish			X			

MAINTENANCE

EMISSION PARTS MAINTENANCE CHART							
PART	MAINTENANCE	BEFORE USE	MONTHLY or 50 HOURS USE	THREE MONTHS or 150 HOURS USE	SIX MONTHS or 300 HOURS USE	YEARLY or 600 HOURS USE	SEE PAGE
Air Filter Element	Clean	X					21
	Replace			X			
Spark Plug	Check / Clean / Adjust		X				20
	Replace				X		
Carburetor	Clean (*1)			X			18,19
	Overhaul (*2) / Replace (*3)					X	

(*1) • At an authorized Cub Cadet Commercial servicing facility to be charged.

(*2) • For consumer use / At an authorized Cub Cadet Commercial servicing facility to be charged.

(*3) • For commercial use / At an authorized Cub Cadet Commercial servicing facility to be charged.

NOTE:

Time intervals shown are a maximum. Actual use and your experience will determine the frequency of required maintenance.

You should be charged for the cost of any required replacement except warranty replacement under LIMITED WARRANTY and/or EMISSION CONTROL WARRANTY.

A. CARBURETOR ADJUSTMENT.

The carburetor is preset at the factory. This is the optimum setting under the barometric pressure and climatic conditions at the factory and is suitable for most operating sites.

It ensures that your machine will run smoothly, be fuel efficient, operate reliably and produce low emissions.

If the engine runs unsatisfactorily at high altitudes or at sea level, slight readjustment of the carburetor may be necessary:

NOTE

Every unit is run at the factory and the carburetor is set in compliance with EPA. In addition, the carburetor is equipped with H and L needle adjustment limiters that prevent settings outside acceptable limits.

1. Check the air filter and clean it if necessary.
2. Check the spark arresting screen (if fitted) and clean it if necessary.

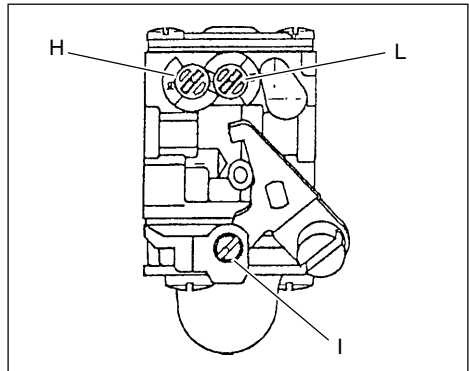

3. Mount the cutting tool.
 - a. Nylon line trimmer head: Trim lines to the correct length. (The lines must extend as far as the line limiting blade on the deflector.
4. Start the engine and adjust the idling speed correctly with the idle speed adjusting screw (Ref. I). The cutting tool must not rotate.
5. Warm up the engine.

6. Adjusting the idle speed:

It is usually necessary to change the setting of the idle speed adjusting screw (Ref. I) after every correction to the low speed adjusting screw (Ref. L).

7. Proper idling speed:

ST23,26..... 2,800-3,000 rpm

ST35..... 2,500-2,700 rpm

8. The engine stops while idling:

Turn the idle speed adjusting screw (Ref. I) clockwise until the engine runs smoothly, but the cutting tool must not rotate.

9. The cutting tool rotates when the engine is idling:

Turn the idle speed adjusting screw (Ref. I) counterclockwise until the cutting tool stops rotating then return the screw about another half turn from that position.

10. Erratic idling behavior, poor acceleration:

The idle setting is too lean. Turn the low speed adjusting screw (Ref. L) counterclockwise until the engine runs and accelerates smoothly.

11. Adjusting high speed:

Adjust the low adjustment screw (Ref. L) for the smooth engine idling. Then increase the engine speed and adjust the high speed adjustment screw (Ref. H) for stable engine rotation. The engine acceleration should be smooth with proper adjustment.

(High Engine Speed.....10,000-11,000 rpm)

MAINTENANCE

B. THE THROTTLE WIRE ADJUSTMENT

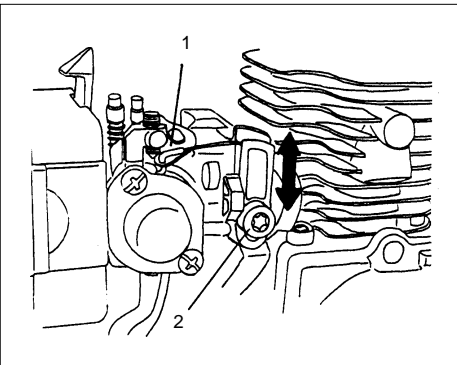
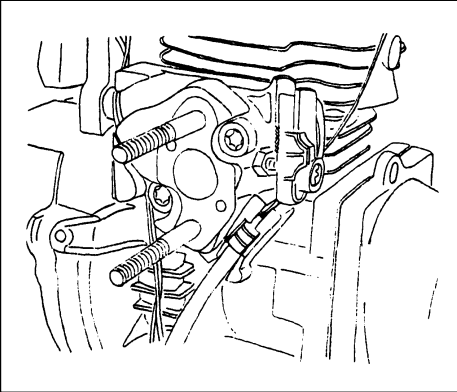

1. Maintain a wire end-play of about 1/16 inch (1-2mm) with the adjuster and fix it with the tightening bolt (Ref.2).



WARNING

To reduce the risk of injury from loss of control, maintain the wire end-play at about 1/16 inch (1-2mm). If the wire end-play is not maintained, engine speed may be enough for the clutch to engage and turn the cutting tool.

C. CHECKING THE SPARK PLUG.

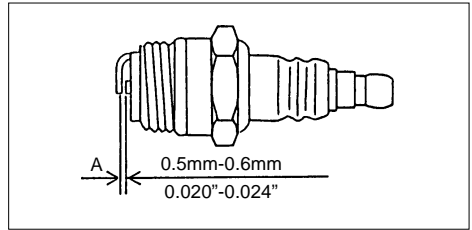

The wrong fuel mix (too much engine oil in the gasoline), a dirty air filter or unfavorable running conditions (mostly at low throttle) affect the condition of the spark plug. These factors cause deposits to form on the insulator nose which may result in faulty operation.

1. If the engine doesn't seem to have any power, is difficult to start or runs poorly at idling speed, first check the spark plug.
2. Remove the spark plug and see "3. If the Engine Doesn't Start" on page 14.
3. Clean the dirty spark plug.
4. Check the electrode gap. It should be 0.20in.(0.5mm) - 0.024in.(0.6mm) Re-gap if necessary.
5. Use only a suppressed spark plug of the approved type:
NGK BPMR7A
Correct the problems which caused the fouling of the spark plug:
Incorrect carburetor setting, too much oil in the fuel mix, dirty air filter, unfavorable running conditions, e.g. operating at partial load.

D. CLEANING THE AIR FILTER.

Dirty air filters reduce engine power, increase fuel consumption and make starting more difficult. If there is a noticeable loss of engine power:

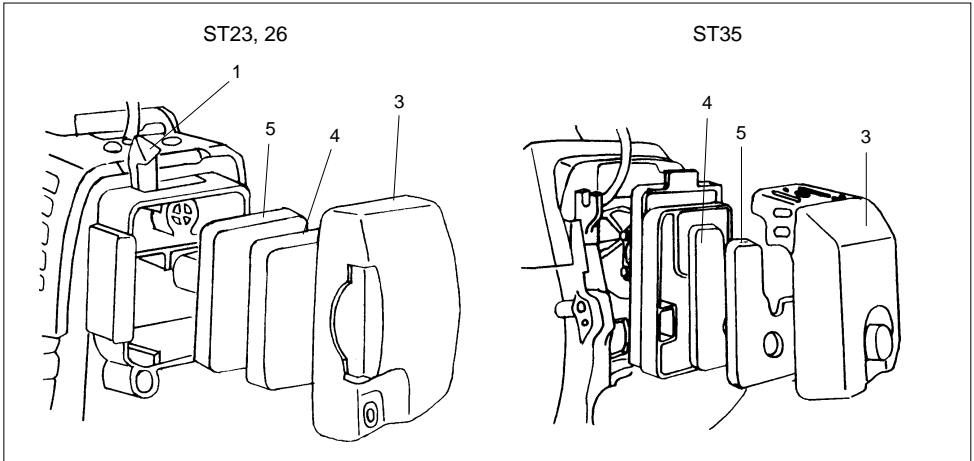

1. Turn the choke lever (Ref. 1) to “CLOSE”. Loosen the screw (Ref. 2) and remove the air filter cover (Ref. 3).
2. Remove the foam element (Ref 4) and felt element (Ref.5).
3. Wash the air filter in warm, soapy water and dry.
4. Always replace a damaged foam element.
5. Fit the foam element in the filter housing.
6. Fit the filter cover and engage it in position.
7. Tighten the screw firmly.

E. COOLING SYSTEM MAINTENANCE.

The cooling system relies on cooling air entering the engine through the bottom engine grille located between the fuel tank and starter. The cooling fan pushes this air through the cylinder fin area and out the rear grille openings in the engine cover.

IMPORTANT
To maintain proper engine operating temperatures, cooling air must pass freely through the cylinder fin area. This flow of air carries combustion heat away from the engine.

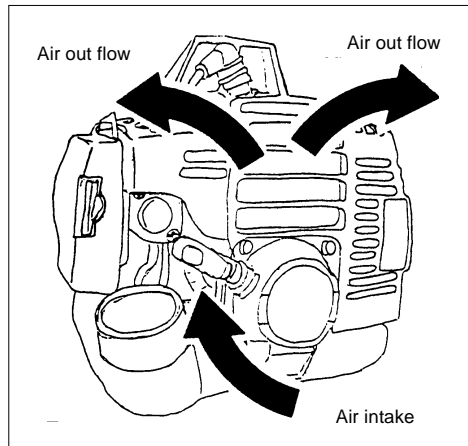

Overheating and engine seizure can occur when:

1. Air intakes are blocked, preventing cooling air from reaching the cylinder.

MAINTENANCE

2. Dust and grass build up on the outside of the cylinder. This buildup insulates the engine and prevents the heat from leaving.

Removal of cooling passage blockages or cleaning of cylinder fins is considered "Normal Maintenance". Any resultant failure attributed to lack of maintenance is not warranted.

F. CLEANING THE CYLINDER FINS.

(Check Periodically)

1. Remove any dust and dirt from between the fins.
2. If greater access is needed to thoroughly clean the fins, remove the engine cover as illustrated.

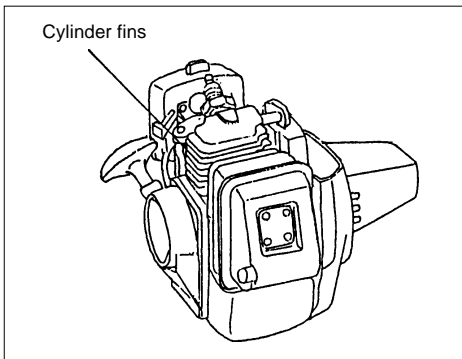

G. CLEANING THE EXHAUST PORT.

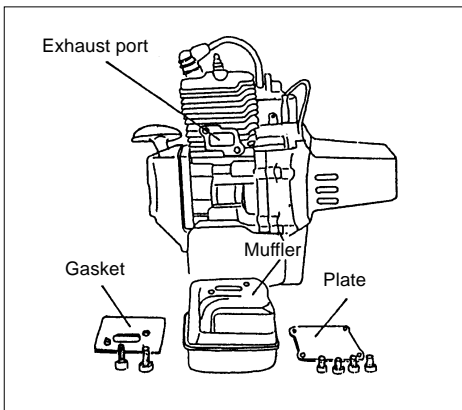

1. Remove the muffler and gasket.

2. Place the piston at top dead center. Clean any deposits from the muffler and the cylinder exhaust port with a nonmetallic scraper.

This procedure requires specialized engine service techniques and the proper tools. Contact the authorized Cub Cadet Commercial dealer where you bought your trimmer or your nearest Cub Cadet Commercial Service Center.

IMPORTANT

Do not use a metal tool to scrape carbon from the exhaust port. Be careful not to scratch the cylinder or piston when cleaning the cylinder exhaust port.

3. Inspect the gasket, and replace it if necessary.
4. Install the muffler.
5. Fit the gasket and cover.

H. CLEANING THE CLUTCH AND CLUTCH DRUM.

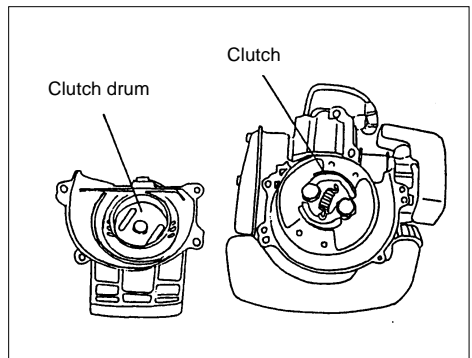

1. Loosen the four screws and remove the fan housing.
2. Clean the dirty clutch and clutch drum.
3. Always replace a damaged clutch and clutch drum.

MAINTENANCE

I. FUEL SYSTEM.

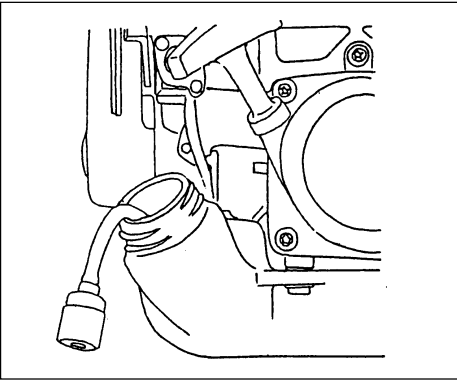

1. Change the fuel pick up body every year.
2. Before storing your machine for a long period, drain and clean the fuel tank and run the engine until the carburetor is dry.
3. The fuel tank and the container in which the fuel mix is stored should be cleaned from time to time.

J. LUBRICATING THE GEAR HEAD.

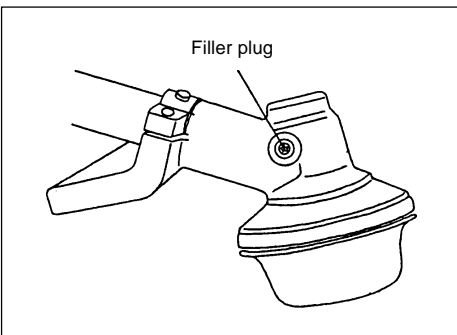

1. Remove the filler plug.
2. Check the level and add grease, if necessary, using a pressure pump. Leave about 5-10 g (1/4 oz.) for any expansion of grease.

NOTE:

Use a good quality lithium multipurpose grease. DO NOT overfill the housing.

3. Tighten the filler plug firmly.

K. LUBRICATING THE DRIVE SHAFT.

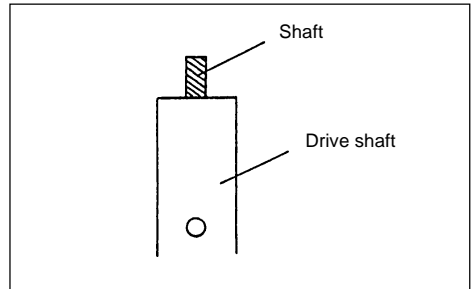

1. Pull the shaft out of the drive tube.
2. Use a good quality lithium multipurpose grease to coat any dry areas of the shaft. Do not apply too much grease. Never pump grease into the drive tube.

TROUBLESHOOTING GUIDE

PROBLEM	CAUSE	SOLUTION
No Fuel at Carburetor	Fuel Filter Dirty Fuel Line Clogged Carburetor	Replace Clean See your Cub Cadet dealer
No Fuel at Cylinder	Carburetor	See your Cub Cadet dealer
Muffler Wet with Fuel	Fuel Mixture is too Rich	Open Choke Clean/Replace Air Filter Adjust Carburetor See your Cub Cadet dealer
No Spark at Plug End of Wire	Ignition Switch Off Electrical Problem	Turn Switch On See your Cub Cadet dealer
No Spark at Spark Plug	Spark Gap Incorrect Covered with Carbon Fouled with Fuel Spark Plug Defective	Re-gap 0.22in.(0.55mm) Clean or Replace Clean or Replace Replace
Engine Does Not Crank or Turn Over	Internal Engine Problem	See your Cub Cadet dealer
Engine Dies or Accelerates Poorly	Air Filter Dirty Fuel Filter Dirty Fuel Vent Plugged Spark Plug Carburetor Cooling System Plugged Exhaust Port Fouled Spark Arrestor Screen Plugged	Clean or Replace Replace Clean Fuel Vent Clean and Adjust or Replace Adjust Clean Clean Clean
No Rotation of Cutting Tool	Incorrect Mounting Twining of String or Grass Around Cutting Tool Wear of Clutch Shoe or Drum	Remount Clean Replace
Grass or Brush Not Being Cut	Dull Cutting Tool Tool Not Mounted Properly	Resharpener and Remount Remount Tool Properly
Excessive Vibration	Loosened Bolt Securing the Tool Incorrect Mounting Bent or Damaged Cutting Tool Cutting Tool Out of Balance Loosened Bolt And Nut	Tighten Remount Replace Tool Replace Tool Tighten

MANUFACTURER'S LIMITED WARRANTY FOR:



Cub Cadet Corporation's limited warranty promises to you, the original retail purchaser, that the unit of Cub Cadet Commercial hand held power equipment you purchased (the "Product") will be free from defects in material and workmanship for, as applicable: a period of one (1) year from the date of retail purchase for commercial purchasers and/or users, and a period of two (2) years from the date of retail purchase for residential purchasers and/or users (the "Warranty period"). Cub Cadet Commercial agrees to repair or replace, at Cub Cadet Commercial's option, any defective Product free of charge during the applicable Warranty Period. Upon completion of your purchase, the Serial Number of the Product will be registered with Cub Cadet Corporation. This will initiate and validate your limited warranty and the applicable Warranty Period. Please keep your purchase receipt and present it to an authorized Cub Cadet Commercial servicing facility for warranty service. Parts replaced or repaired under this limited warranty are warranted only to the end of the Warranty Period. All defective parts replaced under this Limited Warranty become the property of Cub Cadet Corporation. For warranty service, you must, at your own expense, deliver the Product to, and pick it up from, an authorized Cub Cadet Commercial servicing facility. To locate your nearest authorized Cub Cadet Commercial servicing facility, call Cub Cadet Corporation at 330-273-4550.

EXTENDED LIFETIME OF THE PRODUCT LIMITED WARRANTY FOR STRING TRIMMER SHAFT AND TUBE.

If applicable, Cub Cadet Corporation's limited warranty further promises to you, the original retail purchaser, that the shaft and tube of the string trimmer unit you purchased will be free from defects in material and workmanship for the expected life of the Products not to exceed ten (10) years from the date of retail purchase ("Extended Warranty Period"). Cub Cadet Commercial agrees to repair or replace at Cub Cadet Commercial's option, any defective shaft and/or tube of a string trimmer unit free of charge during the Extended Warranty Period. Parts replaced or repaired under this limited warranty are warranted only to the end of the Extended Warranty Period.

This limited warranty is given by Cub Cadet Commercial to the original retail purchaser only, and is not transferable to subsequent owners. This warranty does not cover damage to the Product resulting from any cause other than defects in material or workmanship. This warranty specifically does not cover damage caused by:

1. Lack of lubrication or engine failure due to the use of oils other than Cub Cadet Commercial-approved oils.
2. The use of gasohol containing methyl (wood) alcohol or gasoline containing less than 89 octane or higher or gasohol which contains a maximum 10% ethyl (grain) alcohol or 15% MTBE (methyl tertiary-butyl ether). (The prescribed mixing ratio of gasoline to oil is listed on the Cub Cadet Commercial oil label.)
3. Defects, malfunctions or failures resulting from abuse, misuse, modifications, alterations, improper servicing or maintenance, improper storage, use of unauthorized attachments, including, without limitation, failure to provide or perform required maintenance services as described in the Operator's Manual.
4. Tampering with engine speed governors or running engines above specified and recommended engine speeds.
5. Dirt, salt water corrosion, rust, varnish and moisture.
6. Operation of the Product with improperly serviced, damaged or removed air filter.
7. Failure to follow the set-up, pre-delivery service and adjustments outlined in the Operator's Manual.
8. Parts which are not warranted. (This limited warranty does not cover parts which are normal wear or maintenance items, including, without limitation, spark plugs, filters, lubricants, engine tune-up parts, spark arrestor screen, cutting line and starter cords.)
9. Engine damage caused by the use of ether or any starting fluids.
10. Damage caused by the pressure of steam cleaning the Product.
11. Repairs or alterations made to the Product by an unauthorized party.

THIS LIMITED WARRANTY IS IN PLACE OF ALL OTHER EXPRESS AND IMPLIED WARRANTIES. ANY IMPLIED WARRANTY, SUCH AS FITNESS FOR A PARTICULAR PURPOSE OR MERCHANTABILITY, IS EXCLUDED. REPAIR OR REPLACEMENT UNDER THIS LIMITED WARRANTY IS EXPRESSLY AGREED TO BE THE EXCLUSIVE REMEDY. CUB CADET CORPORATION WILL NOT BE LIABLE FOR ANY SPECIAL, INCIDENTAL OR CONSEQUENTIAL DAMAGES.

SOME STATES DO NOT ALLOW LIMITATIONS ON HOW LONG AN IMPLIED WARRANTY LASTS. SO THE ABOVE LIMITATION MAY NOT APPLY TO YOU. SOME STATES DO NOT ALLOW THE EXCLUSION OR LIMITATION OF INCIDENTAL OR CONSEQUENTIAL DAMAGES. SO THE ABOVE LIMITATIONS MAY NOT APPLY TO YOU. THIS WARRANTY GIVES YOU SPECIFIC LEGAL RIGHTS, AND YOU MAY ALSO HAVE OTHER LEGAL RIGHTS WHICH VARY FROM STATE TO STATE.

HOW TO ORDER PARTS

Contact your Cub Cadet Commercial Salesperson, OR phone us (use the numbers below), OR write us (use the address below). We will need the following information:

1. Your account number if available.
2. Your name and address and the address where you want the parts to be shipped.
3. The Model/Serial No. of the equipment.
4. The Cub Cadet Commercial Part No. and the quantity desired. (Please do not use reference numbers.)

NOTE: Inspect all shipments on receipt for damage or missing parts. File a claim with the carrier before accepting a damaged shipment.

We reserve the right to change designs, specifications and equipment at any time without notice and without incurring any obligations.

CUB CADET CORPORATION, P.O.Box 368023,
Cleveland, OH 44136-9723
Phone (330) 273-4550, Fax (330) 225-9133



U. S. EPA EMISSION CONTROL WARRANTY STATEMENT

YOUR WARRANTY RIGHTS AND OBLIGATIONS

The U.S. Environmental Protection Agency (EPA), Cub Cadet Corporation and the engine manufacturer for this equipment, Ishikawajima Shibaura Machinery Co., Ltd. (ISM), are pleased to explain the federal emission control systems warranty on your engine.

In the U. S. (exclude the state of California), new 1997 and later model year engines must be designed, built, and equipped, at the time of sale, to meet the EPA regulations for small nonroad engines. The engine must be free from defects in materials and workmanship during the period of warranty coverage (see PERIOD OF WARRANTY COVERAGE below). ISM must warrant the emission control system on your engine for that period provided there has been no abuse, neglect or improper maintenance of your engine.

Your emission control system may include parts such as the carburetor and the ignition system (see EMISSION CONTROL WARRANTY PARTS LIST below).

Where a warrantable condition exists, Cub Cadet Corporation will repair your engine at no cost to you, including diagnosis, parts, and labor, on behalf of ISM. While ISM is ultimately responsible for this warranty, Cub Cadet Corporation has agreed to carry out ISM's warranty repair responsibilities, and Cub Cadet Corporation should be your primary contact for emission-related warranty service.

PERIOD OF WARRANTY COVERAGE

1997 and later utility and small nonroad engines are warranted for **two years**. If any emission-related part on your engine is defective, the part will be repaired or replaced by Cub Cadet Commercial on behalf of ISM.

OWNER'S RESPONSIBILITIES

- (a) As the engine owner, you are responsible for the performance of the required maintenance listed in your Operator's Manual. Cub Cadet Commercial and ISM recommend that you retain the original purchase documentation and all receipts covering maintenance on your engine, but Cub Cadet Commercial and ISM cannot deny warranty solely for the lack of receipts or for your failure to ensure the performance of all scheduled maintenance.
- (b) As the engine owner, you should be aware, however, that Cub Cadet Commercial and ISM may deny you warranty coverage if your engine or a part has failed due to abuse, neglect, improper maintenance or unapproved modifications.
- (c) You are responsible for presenting your engine to an authorized Cub Cadet Corporation servicing facility as soon as a problem exists. The warranty repairs should be completed in a reasonable amount of time, not to exceed 30 days.

If you have any questions regarding your warranty rights and responsibilities, call Cub Cadet Corporation at 330-273-4550. You may also contact ISM's representative at 1-916-431-6677.

WARRANTY STATEMENT

The warranty period referred to above begins on the date the equipment (or engine if sold separately) is first sold to a retail purchaser.

ISM warrants to the initial retail purchaser and each subsequent owner that this engine is designed, built, and equipped to conform at the time of initial sale to all applicable regulations of EPA, and that the engine is free of defects in materials and workmanship that would cause it to fail to conform with EPA regulations during its warranty period.

For the parts listed under EMISSION CONTROL WARRANTY PARTS LIST below, an authorized Cub Cadet Commercial servicing facility will, at no cost to you, make the necessary diagnosis, repair, or replacement of any defective part to ensure that the engine complies with applicable EPA regulations.

Any warranted part which is not scheduled for replacement as required maintenance, or which is scheduled only for regular inspection, is warranted for the warranty period. Any part repaired or replacement part installed under this warranty shall be warranted for the remainder of the warranty period.

WARRANTY STATEMENT (continued)

Any warranted part which is scheduled for replacement as required maintenance is warranted for the period of time up to the point of first scheduled replacement. A replacement part installed prior to the first scheduled replacement due to a defect in the original part shall be warranted until the date of the first scheduled replacement. The owner is responsible for the performance of all required maintenance listed in the Operator's Manual.

EMISSION CONTROL WARRANTY PARTS LIST

The parts listed below are covered by this warranty.

- **Carburetor**
- **Ignition system (ignition module)**
- **Spark plug**
- **Air filter element**
- **Insulator (intake manifold)**
- **Fasteners for emission-related parts**

Any parts replaced under this warranty become the property of Cub Cadet Commercial and ISM.

WHAT IS NOT COVERED

This warranty shall not cover any of the following:

- (a) Conditions resulting from tampering, misuse, abuse, improper adjustment, engine alteration, use of add-on or modified parts, use of replacement parts that are not approved by ISM, accident, failure to use the recommended fuel or oil, use of additives to fuel or oil, use of stale fuel more than 30 days old, or not performing required maintenance.
- (b) Replacement parts used for required maintenance.
- (c) Consequential damages such as loss of time, inconvenience, or loss of use of this engine or equipment; however, Cub Cadet Commercial and ISM are liable for damages to other engine components caused by the failure of a warranted part while it is still under warranty.
- (d) Damages or repair costs caused by the owner's unreasonable delay in making the engine available for inspection and repair.
- (e) Fees for diagnosis or inspection that does not result in eligible warranty service being performed.
- (f) Any replacement parts that are not approved by ISM, or malfunction of approved parts due to use of unapproved parts.

Subject to the limitation above, non-warranty maintenance of emission control parts that is required in Operator's Manual may be performed by the owner, or by any repair establishment or individual, without affecting coverage under this warranty; however, warranty repairs must be performed by an authorized Cub Cadet Commercial servicing facility.

The use of parts that are not equivalent in performance and durability to ISM-approved parts may impair the effectiveness of the emission control system and prevent coverage under this warranty. If non ISM-approved parts are used for non-warranty maintenance or replacement on this engine, you should assure yourself that such parts are warranted by their manufacturer to be equivalent to ISM-approved parts in performance and durability.

HOW TO OBTAIN WARRANTY SERVICE

To obtain service under this warranty, promptly take your engine to the nearest authorized Cub Cadet Commercial servicing facility. If available, bring the original purchase receipt (showing the initial date of purchase) and all available maintenance records.

If you need assistance in locating the nearest authorized Cub Cadet Commercial servicing facility or have any questions regarding your warranty rights and responsibilities, call Cub Cadet Corporation at 330-273-4550. You may also contact ISM's representative at 1-916-431-6677.

ST23

ST26

ST35

Trimmers

Parts List



ENGINE, ST23 TRIMMER

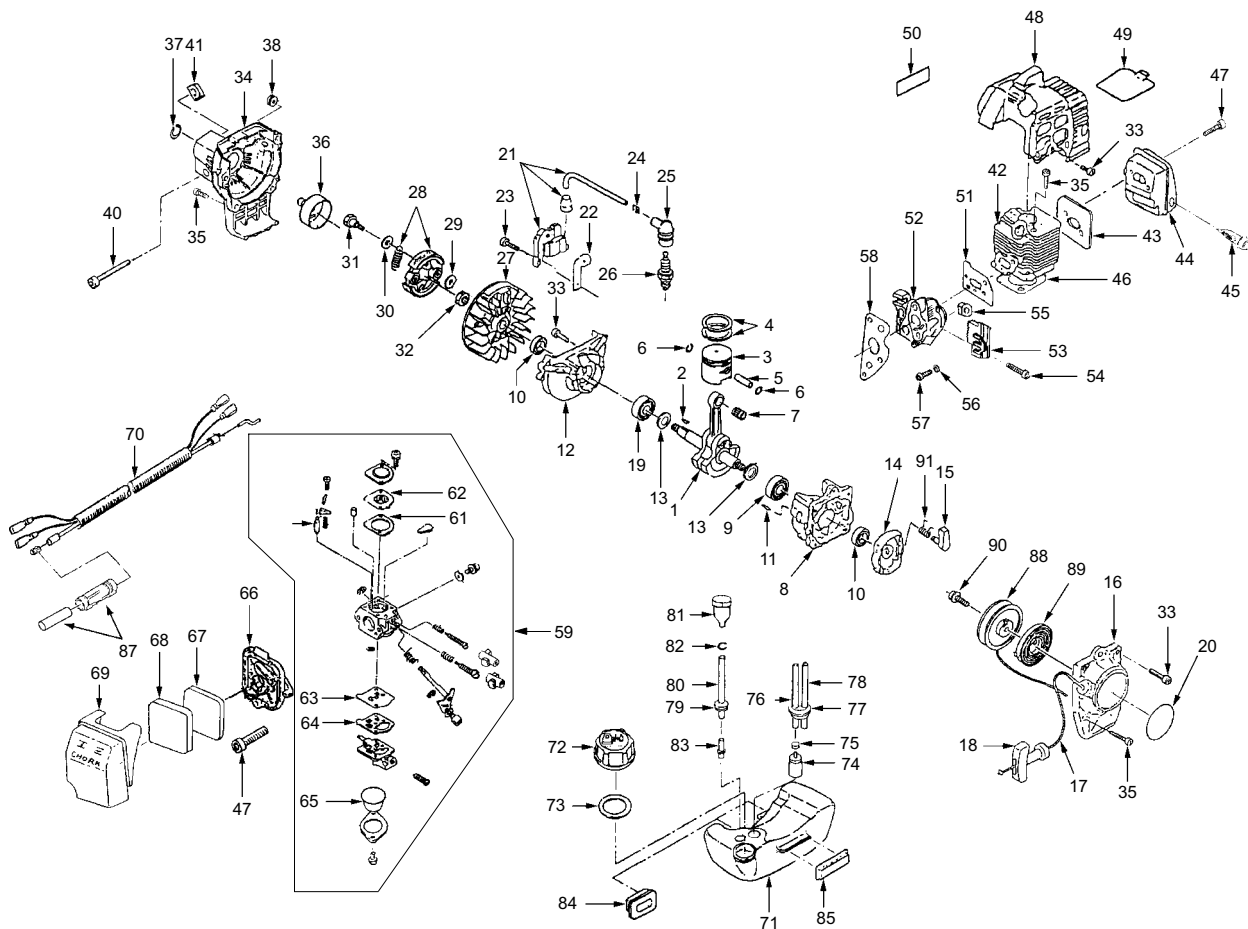

ENGINE, ST23 TRIMMER – PARTS LIST

Ref. No.	Parts No.	Description	No. Used	Ref. No.	Parts No.	Description	No. Used	Ref. No.	Parts No.	Description	No. Used	
	1	IM-115253421	Crankshaft	1	26	IM-150265091	Spark Plug	1	60	IM-130153240	Valve, Float	1
	2	IM-034309031	Key	1	27	IM-150103460	Flywheel, Magneto	1	61	IM-130123350	Gasket	1
	3	IM-115013300	Piston Assembly (Includes 2 Ref. 4)	1	28	IM-170033220	Clutch Assembly	1	62	IM-130283357	Diaphragm, Metering	1
	4	IM-115113650	Ring, Piston	2	29	IM-199213150	Spacer	2	63	IM-130513409	Diaphragm, Pump	1
	5	IM-115323130	Pin, Piston	1	30	IM-199213221	Spacer	2	64	IM-130513413	Gasket	1
	6	IM-198343210	Clip, Piston Pin	2	31	IM-199433071	Bolt	2	65	IM-198113900	Rubber	1
	7	IM-042709007	Bearing, Needle	1	32	IM-020109118	Nut	1	66	IM-135713490	Case, Air Silencer	1
	8	IM-110035180	Crankcase Assembly (Includes 1 ea. Ref. 9,10 and 2 ea. Ref. 11)	1	33	IM-010709009	Bolt, M5x20	5	67	IM-135263310	Element "B", Air Filter	1
	9	IM-040106000	Bearing, Ball, 6000	1	34	IM-170103460	Housing, Blower	1	68	IM-135263300	Element "A", Air Filter	1
	10	IM-050209097	Seal, Oil	2	35	IM-010709008	Bolt, M5x16	8	69	IM-135713480	Cap, Case	1
	11	IM-030500512	Pin, Dowel	2	36	IM-170333220	Drum, Clutch	1	70	IM-125504680	Wire Complete, Throttle	1
N	12	IM-110035131	Crankcase Assembly (Includes 1 ea. Ref. 10 and 19)	1	37	IM-036100010	Snap Ring, S-10	1	71	IM-160113270	Tank, Fuel	1
	13	IM-199283050	Shim, 0.1mm As Req'd.		38	IM-298111010	Grommet	1	72	IM-160033200	Cap Assembly, Fuel Tank (Includes 1 Ref. 73)	1
		IM-199283060	Shim, 0.2mm As Req'd.		40	IM-010709011	Bolt, M5x30	1	73	IM-160993100	Gasket	1
	14	IM-155353090	Pulley Assembly, Starter (Includes 1 ea. Ref.15 and 91)	1	41	IM-020109131	Nut	1	74	IM-130303290	Filter, Fuel	1
	15	IM-155163110	Ratchet	1	42	IM-110213550	Cylinder	1	75	IM-198343181	Clip	1
	16	IM-155103461	Recoil Assembly (Includes 1 ea. Ref.17, 18, 88, 89 and 90)	1	43	See Ref.86 - Gasket, Muffler	1	76	IM-130983060	Hose	1	
	17	IM-155213050	Rope, Starter	1	44	IM-135403500	Muffler	1	77	IM-198113730	Rubber	1
	18	IM-155223061	Knob, Starter	1	45	IM-135493090	Arrester	1	78	IM-068209150	Hose	1
	19	IM-040106200	Bearing, Ball, 6200	1	46	IM-110993390	Gasket, Cylinder	1	79	IM-198113560	Rubber	1
	20	IM-190285420	Name Plate	1	47	IM-010709016	Bolt, M5x48	4	80	IM-068209177	Hose	1
	21	IM-150053291	Coil Assembly, Ignition	1	48	IM-175154060	Cowling, Cylinder	1	81	IM-160043121	Valve, Reversing	1
	22	IM-199513451	Insulator	1	49	IM-135433470	Baffle Plate	1	82	IM-198343060	Clip	1
	23	IM-010709018	Bolt, M4x20	2	50	IM-190333330	Trade Mark	1	83	IM-198483100	Connector	1
	24	IM-198213300	Spring	1	51	See Ref.86 - Gasket, Insulator	1	84	IM-198113701	Rubber	2	
	25	IM-150413033	Cap, Plug	1	52	IM-199513501	Insulator	1	85	IM-198113740	Rubber	1
					53	IM-125543100	Adjuster	1	86	IM-135994150	Gasket Kit (Includes 1 ea. Ref. 43, 51 and 58)	1
					54	IM-010709006	Bolt, M5x12	4	87	IM-125683061	Wire Holder	1
					55	IM-020100005	Nut	1	88	IM-155183121	Reel	1
					56	IM-026100005	Washer	2	89	IM-155263270	Spring, Spiral	1
					57	IM-010709010	Bolt, M5x25	2	90	IM-155343050	Screw	1
					58	See Ref.86 - Gasket	1	91	IM-155263261	Spring, Return	1	
					59	IM-130104240	Carburetor Assembly (Includes 1 ea. Ref. 60, 61, 62, 63, 64 and 65)	1				

SHAFT, ST23 TRIMMER

3

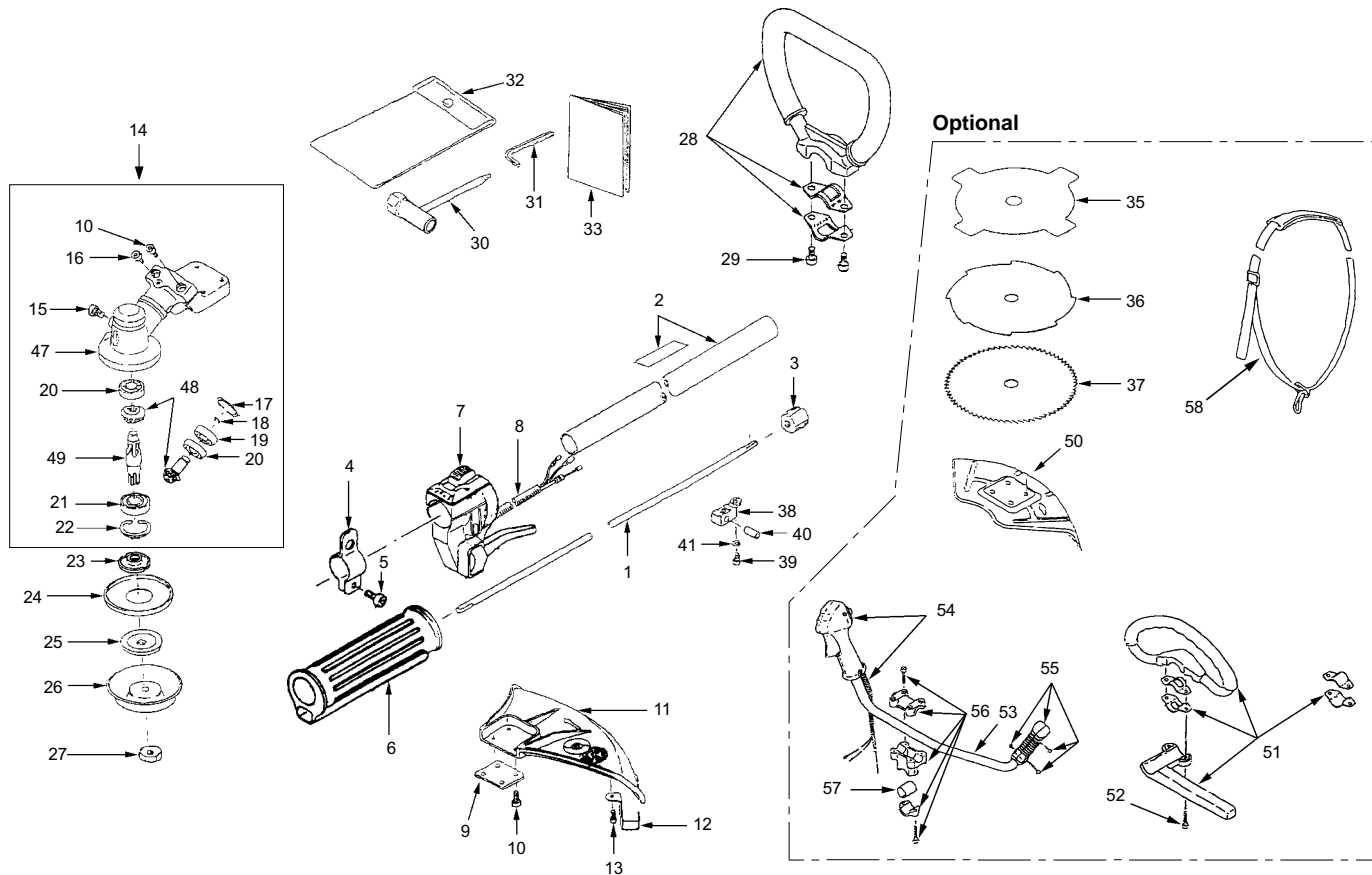

ENGINE, ST26 TRIMMER

1

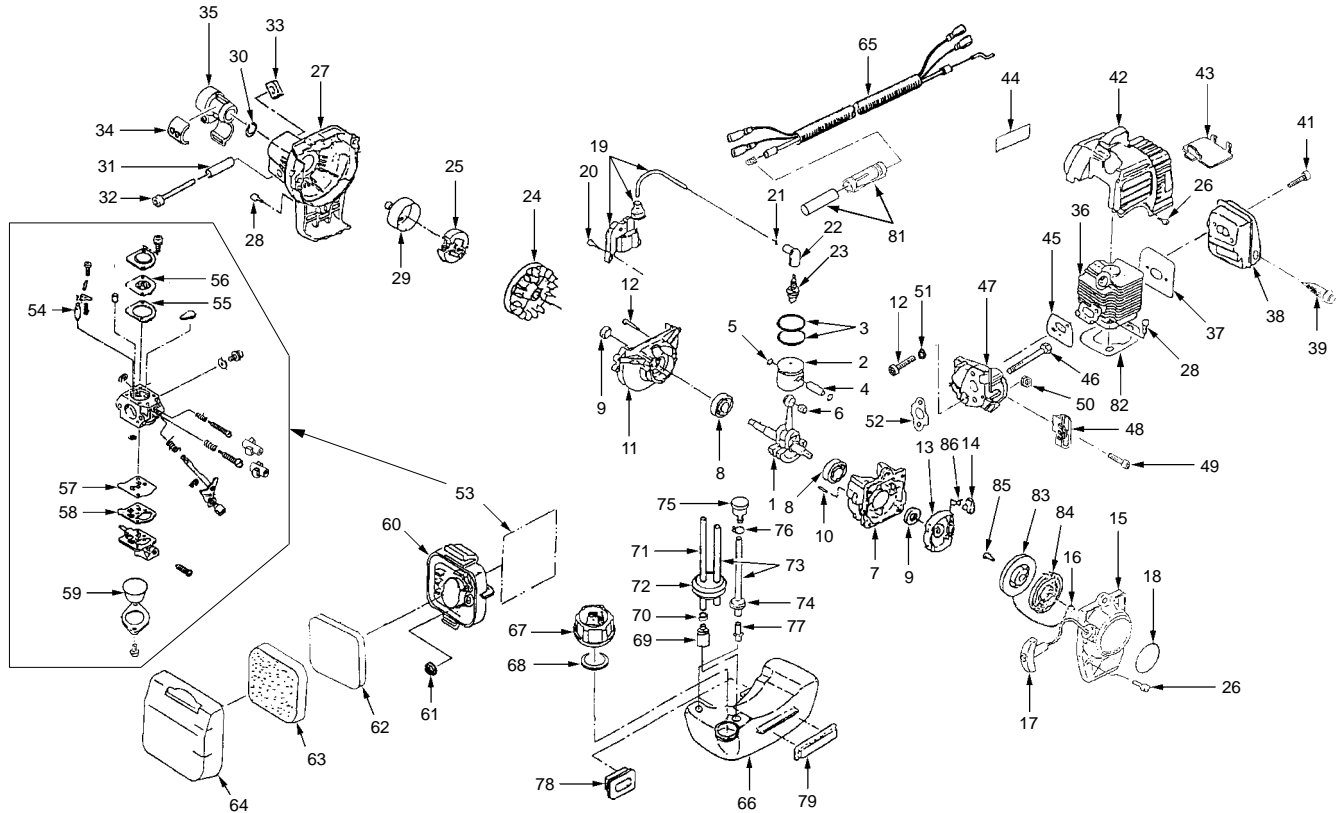

ENGINE, ST26 TRIMMER – PARTS LIST

Ref. No.	Parts No.	Description	No. Used	Ref. No.	Parts No.	Description	No. Used	Ref. No.	Parts No.	Description	No. Used
1	IM-115253470	Crankshaft	1	26	IM-010709009	Bolt, M5x20	4	59	IM-198113900	Rubber	1
2	IM-115013311	Piston Assembly (Includes 2 Ref. 3)	1	27	IM-175103470	Housing, Blower	1	60	IM-135713490	Case, Air Silencer	1
3	IM-115113650	Ring, Piston	2	28	IM-010709008	Bolt, M5x16	5	61	IM-023100005	Nut	2
4	IM-115323040	Pin, Piston	1	29	IM-170333240	Drum, Clutch	1	62	IM-135263310	Element "B", Air Filter	1
5	IM-198343210	Clip, Piston Pin	2	30	IM-036100012	Snap Ring, S-12	1	63	IM-135263300	Element "A", Air Filter	1
6	IM-042709008	Bearing, Needle	1	31	IM-199233470	Collar	1	64	IM-135713450	Cap, Case	1
7	IM-110035190	Crankcase Assembly (Includes 1 ea. Ref. 8,9 and 2 ea. Ref. 10)	1	32	IM-010709011	Bolt, M5x30	1	65	IM-125504790	Wire Complete, Throttle	1
8	IM-040106201	Bearing, Ball, 6201	2	33	IM-020109131	Nut	1	66	IM-160113261	Tank, Fuel	1
9	IM-050209070	Seal, Oil	2	34	IM-175423050	Plate	1	67	IM-160033200	Cap Assembly, Fuel Tank (Includes 1 Ref. 78)	1
10	IM-030500512	Pin, Dowel	2	35	IM-198113890	Rubber	1	68	IM-160993100	Gasket	1
11	IM-110035200	Crankcase Assembly (Includes 1 ea. Ref. 8 and 9)	1	36	IM-110213560	Cylinder	1	69	IM-130303290	Filter, Fuel	1
12	IM-010709010	Bolt, M5x25	5	37	See Ref.80 - Gasket, Muffler	1	70	IM-198343181	Clip	1	
13	IM-155353090	Pulley Assembly, Starter (Includes 1 ea. Ref.14 and 86)	1	38	IM-135403670	Muffler (Includes 1 Ref.39) 1	1	71	IM-198163080	Hose	1
14	IM-155163110	Ratchet	1	39	IM-135493090	Arrester	1	72	IM-198113730	Rubber	1
15	IM-155103461	Recoil Assembly (Includes 1 ea. Ref.16, 17, 83, 84 and 85)	1	41	IM-010709016	Bolt, M5x48	2	73	IM-068209150	Hose	2
16	IM-155213050	Rope, Starter	1	42	IM-175154070	Cowling, Cylinder	1	74	IM-198113560	Rubber	1
17	IM-155223061	Knob, Starter	1	43	IM-135433630	Baffle Plate	1	75	IM-160043121	Valve, Reversing	1
18	IM-190285440	Name Plate	1	44	IM-190333330	Trade Mark	1	76	IM-198343060	Clip	1
19	IM-150053330	Coil Assembly, Ignition	1	45	See Ref.80 - Gasket, Insulator	1	77	IM-198483100	Connector	1	
20	IM-010709018	Bolt, M4x20	2	46	IM-010109433	Bolt, M5x56	2	78	IM-198113620	Rubber	2
21	IM-198213300	Spring	1	47	IM-199513510	Insulator	1	79	IM-198113740	Rubber	1
22	IM-150413033	Cap, Plug	1	48	IM-125543100	Adjuster	1	80	IM-135994160	Gasket Kit (Includes 1 ea. Ref. 37, 45 and 52)	1
23	IM-150265091	Spark Plug	1	49	IM-010709006	Bolt, M5x12	1	81	IM-125683061	Wire Holder	1
24	IM-150103500	Flywheel, Magneto	1	50	IM-020100005	Nut	1	82	IM-110993420	Gasket, Cylinder	1
25	IM-170033370	Clutch Assembly	1	51	IM-026100005	Washer	2	83	IM-155183121	Reel	1
				52	See Ref.80 - Gasket	1		84	IM-155263270	Spring, Spiral	1
				53	IM-130104240	Carburetor Assembly (Includes 1 ea. Ref. 54, 55, 56, 57, 58 and 59)	1	85	IM-155343050	Screw	1
				54	IM-130153240	Valve, Float	1	86	IM-155263261	Spring, Return	1
				55	IM-130123350	Gasket	1				
				56	IM-130283357	Diaphragm, Metering	1				
				57	IM-130513409	Diaphragm, Pump	1				
				58	IM-130513413	Gasket	1				

SHAFT, ST26 TRIMMER

3

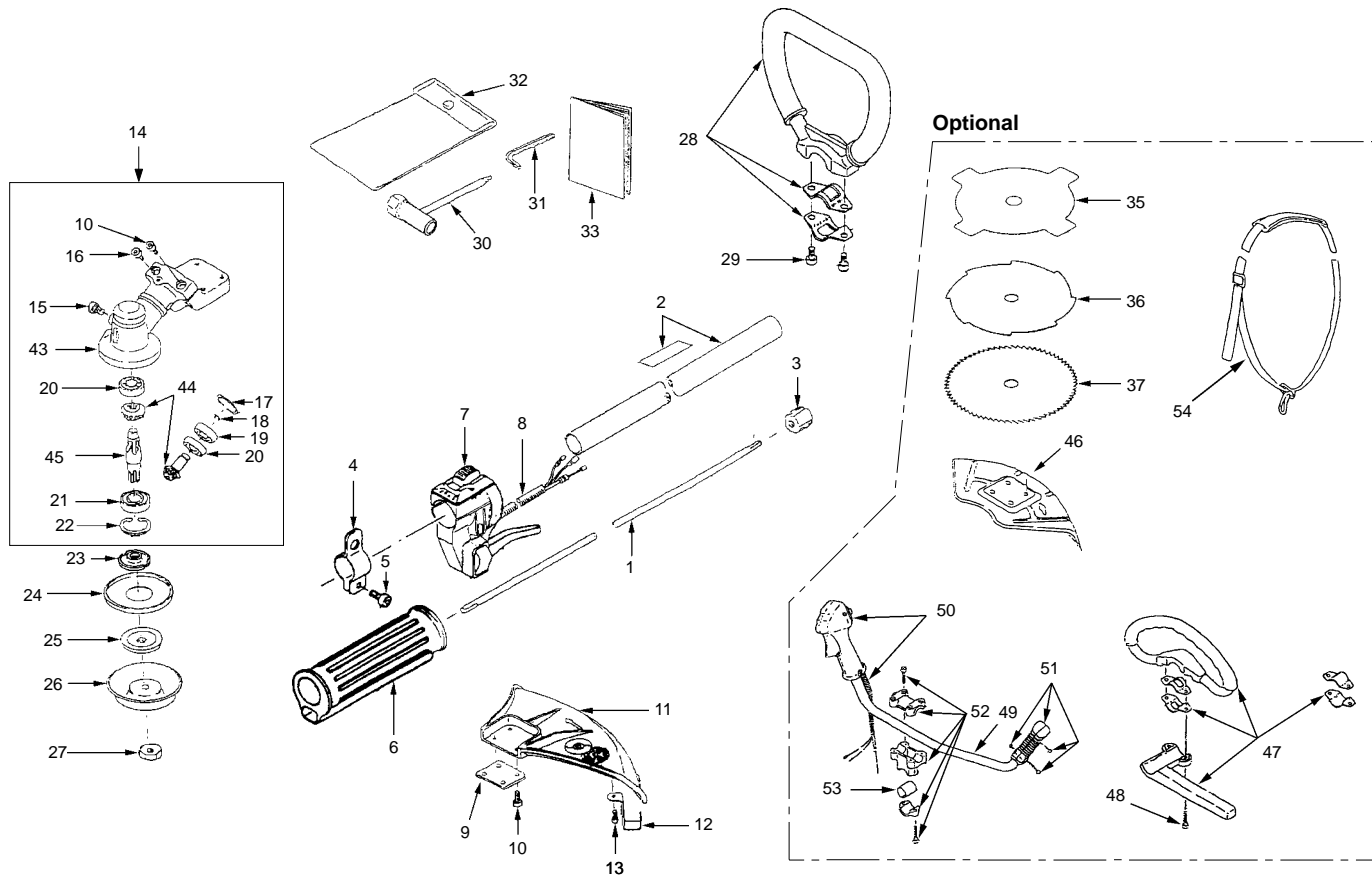

SHAFT, ST26 TRIMMER – PARTS LIST

Ref. No.	Parts No.	Description	No. Used	Ref. No.	Parts No.	Description	No. Used	Ref. No.	Parts No.	Description	No. Used
1	IM-720113160	Shaft, Drive	1	27	IM-720973715	Nut, LH M10x1.25	1	Optional			
2	IM-720124330	Pipe, Complete (Includes 6 Ref. 3)	1	28	IM-720053800	Handle, Loop (Includes 2 Ref. 29)	1	35	IM-195833140	Blade, 4 Tooth	1
3	IM-720133160	Metal	6	29	IM-720973177	Bolt, M6x12	2	36	IM-195833170	Blade, 8 Tooth	1
4	IM-720203082	Hanger	1	30	IM-720983371	Wrench, Spanner Box 19 .	1	37	IM-195833230	Blade, Circular	1
5	IM-720973178	Bolt, M6x14	1	31	IM-090500004	Wrench, Key, 4mm	1	46	IM-720463430	Deflector, Steel	1
6	IM-720623400	Grip	1	32	IM-720983420	Bag, Tool	1	47	IM-720053910	Handle Assembly, Loop (Includes 2 Ref. 48)	1
7	IM-125034130	Lever Assembly, Throttle (Includes 1 Ref. 8)	1	33	IM-100814820	Manual, Operator's	1	48	IM-720973183	Bolt, M6x18	2
8	IM-125504820	Wire Complete, Throttle	1	43	IM-720263660	Case, Gear	1	49	IM-720613420	Handle	1
9	IM-720473180	Plate	1	44	IM-720273190	Gear Assembly	1	50	IM-125034241	Lever Assembly, Throttle ..	1
10	IM-010709009	Bolt, M5x20	6	45	IM-720293360	Shaft	1	51	IM-720623520	Grip Assembly	1
11	IM-720043511	Deflector Assembly, Plastic (Includes 1 ea. Ref. 12 and 13)	1								
12	IM-720493060	Cutter	1								
13	IM-010709008	Bolt, M5x16	1								
14	IM-720023990	Case Assembly, Gear (Includes 1 ea. Ref. 15, 16, 17, 18, 19, 21, 22, 43, 44, 45 and 2 ea. Ref. 10 and 20)	1								
15	IM-720973663	Bolt, M6x8	1								
16	IM-720973175	Bolt, M5x10	1								
17	IM-036500024	Snap Ring, R-24	1								
18	IM-036100009	Snap Ring, S-9	1								
19	IM-720973161	Bearing, Ball, 609ZZ	1								
20	IM-720973159	Bearing, Ball, 609	2								
21	IM-040146001	Bearing, Ball, 6001LL	1								
22	IM-036500028	Snap Ring, R-28	1								
23	IM-720333630	Holder	1								
24	IM-720343890	Cover	1								
25	IM-720333610	Holder	1								
26	IM-720343780	Cover, Nut	1								

ENGINE, ST35 TRIMMER

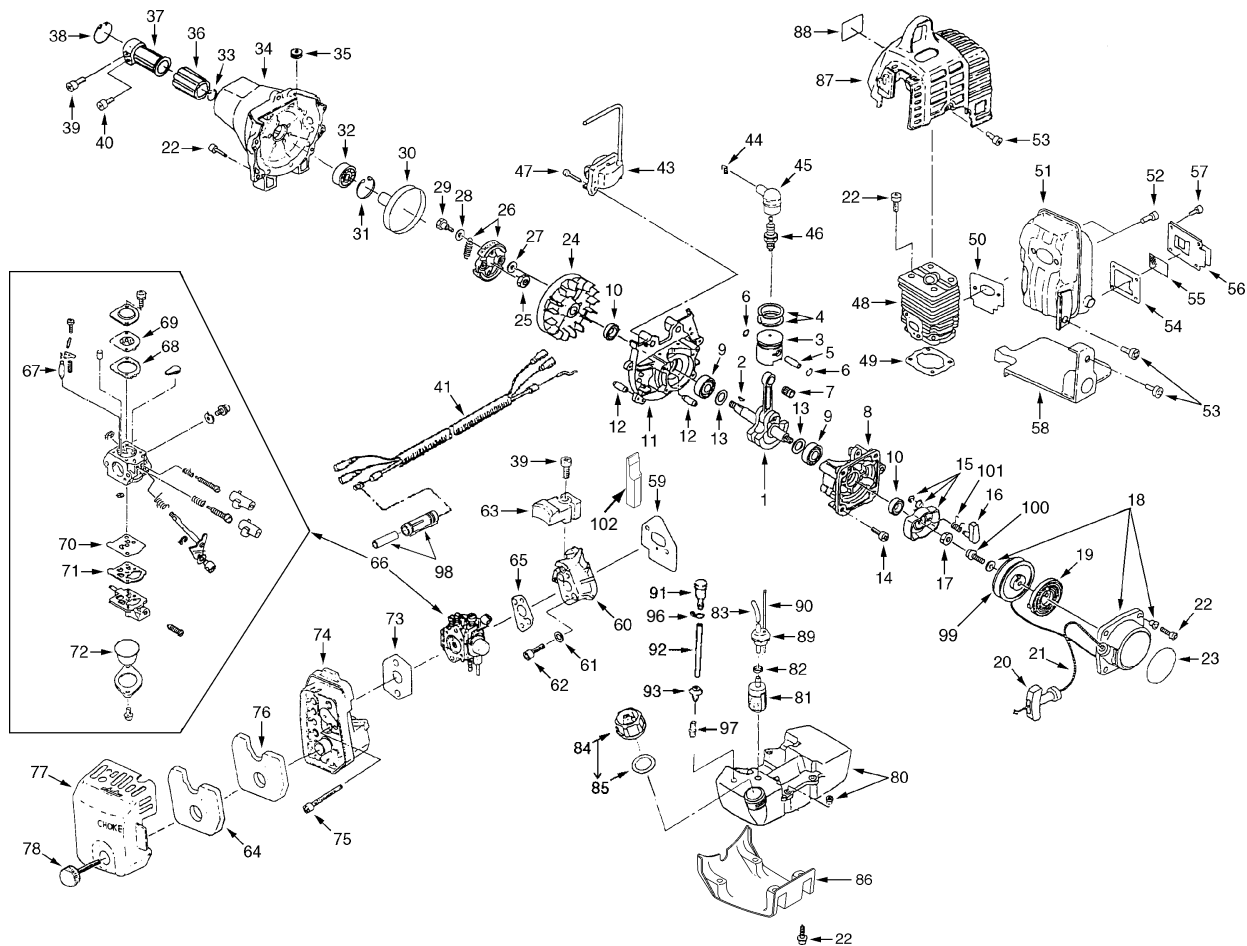

ENGINE, ST35 TRIMMER – PARTS LIST

Ref. No.	Parts No.	Description	No. Used	Ref. No.	Parts No.	Description	No. Used	Ref. No.	Parts No.	Description	No. Used
1	IM-115253440	Crankshaft	1	30	IM-170333140	Drum, Clutch	1	68	IM-130123350	Gasket	1
2	IM-034309031	Key	1	31	IM-036500035	Snap Ring, R-35	1	69	IM-130283357	Diaphragm, Metering	1
3	IM-115013280	Piston Assembly (Includes 2 Ref. 4)	1	32	IM-040126202	Bearing, Ball, 6202ZZ	1	70	IM-130513409	Diaphragm, Pump	1
4	IM-115113730	Ring, Piston	2	33	IM-036100015	Snap Ring, S-15	1	71	IM-130513410	Gasket	1
5	IM-115323030	Pin, Piston	1	34	IM-175114580	Housing, Blower	1	72	IM-198113870	Rubber	1
6	IM-198343040	Clip, Piston Pin	2	35	IM-298111010	Grommet	1	73	See Ref.95 - Gasket, Air Silencer	1	
7	IM-042709006	Bearing, Needle	1	36	IM-198113810	Rubber	1	74	IM-135713373	Case, Air Silencer	1
8	IM-110035150	Crankcase Assembly (Includes 1 ea. Ref. 9 and 10)	1	37	IM-165983130	Pipe	1	75	IM-010709016	Bolt, M5x48	2
9	IM-040106201	Bearing, Ball, 6201	2	38	IM-0366550047	Snap Ring, R-47	1	76	IM-135263380	Element "A", Air Filter	1
10	IM-050209070	Seal, Oil	2	39	IM-010709015	Bolt, M4x12	2	77	IM-135713393	Cap, Case (Includes 1 Ref. 78)	1
11	IM-110035160	Crankcase Assembly (Includes 1 ea. Ref. 9, 10 and 4 ea. Ref. 12)	1	40	IM-010709013	Bolt, M6x20	1	80	IM-160103330	Tank, Fuel	1
12	IM-030500512	Pin, Dowel	4	41	IM-125504840	Wire Complete, Throttle	1	81	IM-130303290	Filter, Fuel	1
13	IM-199283030	Shim, 0.1mm As Req'd		43	IM-150053320	Coil Assembly, Ignition	1	82	IM-198343181	Clip	1
13	IM-199283040	Shim, 0.2mm As Req'd		44	IM-198213300	Spring	1	83	IM-198163080	Hose	1
14	IM-010709011	Bolt, M5x30	4	45	IM-150413033	Cap, Plug	1	84	IM-160033200	Cap Assembly, Fuel Tank (Includes 1 Ref. 85)	1
15	IM-155353060	Pulley Assembly, Starter (Includes 1 ea. Ref. 16 and 101)	1	46	IM-150265091	Spark Plug	1	85	IM-160993100	Gasket	1
16	IM-155163080	Ratchet	1	47	IM-010709009	Bolt, M5x20	2	86	IM-175973400	Stay, Stand	1
17	IM-020300008	Nut	1	48	IM-110213540	Cylinder	1	87	IM-175154080	Cowling, Cylinder	1
18	IM-155103341	Recoil Assembly (Includes 1 ea. Ref.19, 20, 21, 99 and 100)	1	49	IM-110993410	Gasket, Cylinder	1	88	IM-190333330	Trade Mark	1
19	IM-155263210	Spring, Sprial	1	50	See Ref.95 - Gasket, Muffler	1	89	IM-198113730	Rubber	1	
20	IM-155223050	Knob, Starter	1	51	IM-135403492	Muffler	1	90	IM-068209150	Hose	1
21	IM-155213090	Rope, Starter	1	52	IM-010709040	Bolt, M5x58	2	91	IM-160043121	Valve, Reversing	1
22	IM-010709008	Bolt, M5x16	16	53	IM-010709006	Bolt, M5x12	4	92	IM-068209176	Hose	1
23	IM-190285460	Name Plate	1	54	See Ref.95 - Gasket, Baffle Plate	1	93	IM-198113560	Rubber	1	
24	IM-150103351	Flywheel, Magneto	1	55	IM-135493010	Arrester	1	95	IM-135994170	Gasket Kit (Includes 1 ea. Ref.50, 54, 59, 65 and 73)	1
25	IM-020109107	Nut	1	56	IM-135433570	Baffle Plate, Outer	1	96	IM-198343060	Clip	1
26	IM-170033241	Clutch Assembly	1	57	IM-010709014	Bolt, M4x6	4	97	IM-198483100	Connector	1
27	IM-199213071	Spacer	2	58	IM-135433560	Baffle Plate	1	98	IM-125683061	Wire Holder	1
28	IM-199213180	Spacer	2	59	See Ref.95 - Gasket, Insulator	1	99	IM-155183090	Reel	1	
29	IM-199433082	Bolt	2	60	IM-199513550	Insulator	1	100	IM-155343050	Screw	1
				61	IM-026100005	Washer	2	101	IM-155263200	Spring, Return	1
				62	IM-010709010	Bolt, M5x25	2	102	IM-198113940	Rubber	1
				63	IM-125543090	Adjuster	1				
				64	IM-135263370	Element "B", Air Filter	1				
				65	See Ref.95 - Gasket	1					
				66	IM-130104210	Carburetor Assembly (Includes 1 ea. Ref. 67, 68, 69, 70, 71 and 72)	1				
				67	IM-130153210	Valve, Float	1				

SHAFT, ST35 TRIMMER

3

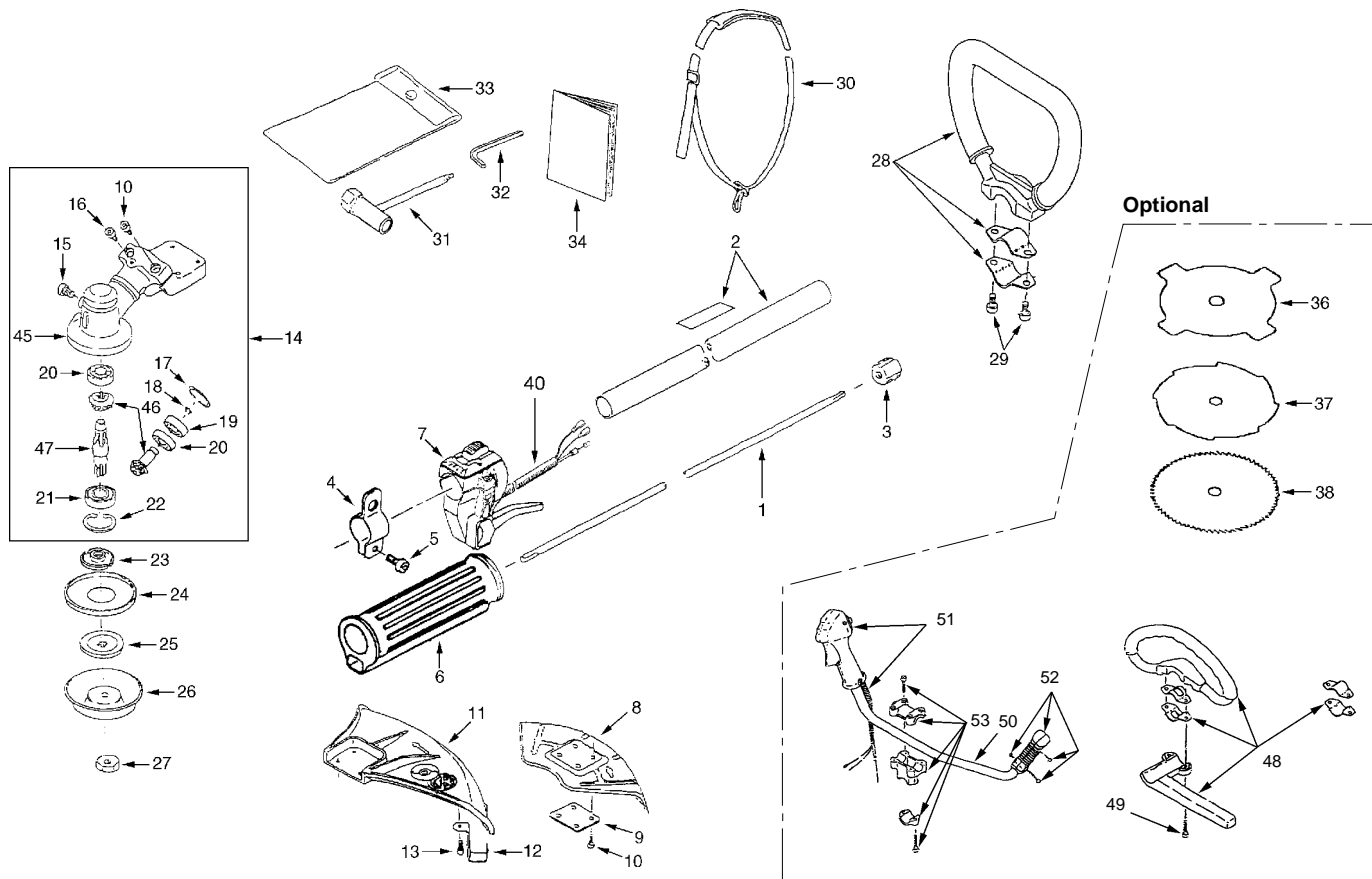

SHAFT, ST35 TRIMMER – PARTS LIST

Ref. No.	Parts No.	Description	No. Used	Ref. No.	Parts No.	Description	No. Used	Ref. No.	Parts No.	Description	No. Used
1	IM-720113120	Shaft, Drive	1	27	IM-720973715	Nut, LH M10x1.25	1	Optional			
2	IM-720124290	Pipe, Complete (Includes 6 Ref. 3)	1	28	IM-720053650	Handle, Loop (Includes 2 Ref. 29)	1	36	IM-195833150	Blade, 4 Tooth	1
3	IM-720133061	Metal	6	29	IM-720973177	Bolt, M6x12	2	37	IM-195833070	Blade, 8 Tooth	1
4	IM-720203073	Hanger	1	30	IM-720853461	Harness, Shoulder	1	38	IM-195833160	Blade, Circular	1
5	IM-720973178	Bolt, M6x14	1	31	IM-720983371	Wrench, Spanner Box 19 .	1	48	IM-720053910	Handle Assembly, Loop (Includes 1 Ref. 49)	1
6	IM-720623251	Grip	1	32	IM-090500004	Wrench, Key, 4mm	1	49	IM-720973183	Bolt, M6x18	2
7	IM-125034150	Lever Assembly, Throttle (Includes 1 Ref. 40)	1	33	IM-720983420	Bag, Tool	1	50	IM-720613420	Handle	1
8	IM-720463430	Deflector, Steel	1	34	IM-100814820	Manual, Operator's	1	51	IM-125034241	Lever Assembly, Throttle ..	1
9	IM-720473180	Plate	1	40	IM-125504820	Wire Compl, Throttle	1	52	IM-720623520	Grip Assembly	1
10	IM-010709009	Bolt, M5x20	6	45	IM-720263670	Case	1	53	IM-720063260	Holder Assembly, Handle .	1
11	IM-720043511	Deflector Assembly, Plastic (Includes 1 ea. Ref. 12 and 13)	1	46	IM-720273160	Gear Assembly	1				
12	IM-720493060	Cutter	1	47	IM-720293370	Shaft	1				
13	IM-010709008	Bolt, M5x16	1								
14	IM-720023940	Case Assembly, Gear (Includes 1 ea. Ref. 15, 16, 17, 18, 19, 21, 22, 45, 46 and 47 and 2 ea. Ref. 10 and 20)	1								
15	IM-720973663	Bolt, M6x8	1								
16	IM-720973175	Bolt, M5x10	1								
17	IM-036500026	Snap Ring, R-26	1								
18	IM-036100010	Snap Ring, S-10	1								
19	IM-040126000	Bearing, Ball, 6000ZZ	1								
20	IM-040106000	Bearing, Ball, 6000	2								
21	IM-040146001	Bearing, Ball, 6001LL	1								
22	IM-036500028	Snap Ring, R-28	1								
23	IM-720333630	Holder	1								
24	IM-720343890	Cover	1								
25	IM-720333610	Holder	1								
26	IM-720343780	Cover, Bolt	1								

